

A Survey on Energy Efficient Routing Protocols for Wireless Sensor Networks

Ramana Boina Kalyani¹

Dhanika srinivas²

^{1,2}Assistant professor,

Electronics and communication Engineering department,

Vignan Institute of Technology and Science-Deshmukhi, Hyderabad, Telangana, India

Abstract—Wireless Sensor Networks (WSNs) domain is among the most embryonic fields in today's rapid developing and smart world with ample applications such as healthcare, wildlife and environmental monitoring, defence, landslide detection etc. Any fundamental wireless sensor network is composed of multiple sensor nodes deployed randomly in order to collect, aggregate and transmits the data to the base station. As the battery of the sensor node can neither be recharged nor be replaced, design of routing protocols having better network lifetime is the critical issue for researchers. Low Energy Adaptive Clustering Hierarchy (LEACH) was the fundamental and traditional routing protocol scheme proposed for WSNs. Advancements and auxiliary improvements in this routing scheme have been done for optimization of the network parameters as per the requirements of the applications. In this paper, the author has surveyed various energy efficient routing protocol schemes which are the enhanced versions of basic LEACH algorithm. The author has also performed a comparative analysis and tabulated that for the surveyed routing schemes.

Keywords: Wireless Sensor Network, Energy Efficient, LEACH, Cluster Head, Clustering, Throughput, Network Lifetime

I. INTRODUCTION

Wireless Sensor Network (WSN) is the collection of low-cost, small-size, light-weight sensor nodes which are capable of sensing, processing, receiving and transmitting the data. The key parameters of a good Wireless Sensor Network (WSN) are better network lifetime, higher throughputs, lesser energy consumption, and cost effectiveness. These sensor nodes can be of different based on their functionality and applications such as infrared, visual, seismic, thermal, acoustic, health monitoring, humidity, radar, pressure, temperature, security surveillance, etc. [1-5]. Also, there are variety of applications of designed Wireless Sensor Networks (WSNs) such as health monitoring, battlefield surveillance, tracking of the vehicle and other devices, and traffic control, etc. for both inhabitants and defense people. In order to design any standard wireless sensor network, reliability, energy consumption, memory of network, network lifetime, bandwidth and security of network are the major parameters to be considered during the design [6].

Design of Wireless Sensor Networks (WSNs) has a lot of significant characteristics followed by multiple controls and constraints. For any application, sensor nodes are deployed randomly in the available coverage area. The deployed sensor nodes categorize and configure themselves in order to form a wireless network to perform the task. Additionally, sensor nodes are powered by limited capacity battery and hence the replacement of discharged batteries and recharging of batteries also becomes one of the most significant constraints for the sensor nodes. Security of the deployed nodes inside the designed wireless network is another matter of concern. Along with these constraints, data redundancy puts another restriction

on the efficiency of the deployed sensor nodes and hence for the designed wireless network. Consequently, the selection and implementation of energy efficient routing protocol for wireless sensor network becomes one of the most prominent areas with the intention of acquiring the security and efficiency during the communication along with a better network lifetime.

The rest of the paper is framed as follows. Section 2 presents the various routing protocol schemes in order to design

the wireless sensor networks. Section 3 presents the different routing protocol schemes for heterogeneous wireless networks discovered in past two decades. Section 4 presents a comparison of different routing protocol schemes for heterogeneous wireless networks as discussed in section 3. Sections 5 present the conclusion of the presented paper.

II. ROUTING SCHEMES FOR DESIGNING WIRELESS SENSOR NETWORKS

All the Routing protocols designed for wireless networks can be largely categorized in four diverse schemes: Communication Model Scheme, Network Structure Scheme, Topology Based Scheme, and Reliable Routing Scheme [7]. In addition to this, these network structures techniques can be auxiliary classified into three different sub-categories based on the deployment of the nodes for the designed network namely as; Location based routing techniques, Flat routing techniques, Hierarchical routing techniques. In location based routing techniques, the address of the deployed sensor is used in order to address them. In these techniques, the distance of the particular node from the neighborhood node is estimated with the extensive use of the signal strength. Also, the nodes will be in sleep mode if they are idle in the network in order to achieve the power saving. In flat routing protocol techniques, the prime objectives and the functions for all the available and deployed sensor nodes of designed sensor network are alike. These techniques have issue of scalability due to which they are only functional and in use barely for very small area networks. Gossiping [8], Negotiation based [9], Directed diffusion [10], Rumor [11] etc. are the most frequently used schemes to design wireless networks based on flat routing protocol techniques.

In contrast to these techniques, hierarchical routing based techniques are used in to achieve the efficiency in terms of both scalability and energy. The architecture of this technique enables these features here. In this technique, the clusters are obtained by dividing the entire area of the designed network. Furthermore, out of the available deployed sensor nodes a small number of nodes are preferred as some distinguished nodes based on some special criterions. These distinguished nodes are recognized as the cluster

heads (CHs). The prime objectives of these distinguished nodes or cluster heads are data aggregation, data collection and to perform the compression for the received data or information from the other surrounding nodes which are available in the closest proximity or neighborhood to these cluster heads. Furthermore, these cluster heads are responsible for the secured and reliable transmission of the compressed, aggregated and collected data or information to the base station which is in the closest neighborhood of these cluster heads. These cluster heads are going to consume more energy as compared to the other available surrounding nodes owing to their multi-functionalities and responsibilities for the cluster in which they reside. On the other hand, a universal cluster rotation policy can be incorporated here which is going to poise an equilibrium for the energy consumption throughout the cluster for designed wireless network. A standard model for hierarchical routing techniques for WSNs is as shown in Fig.-1. Low Energy Adaptive Clustering Hierarchy (LEACH) is the foremost and the earliest hierarchical based routing protocol technique proposed in [12].

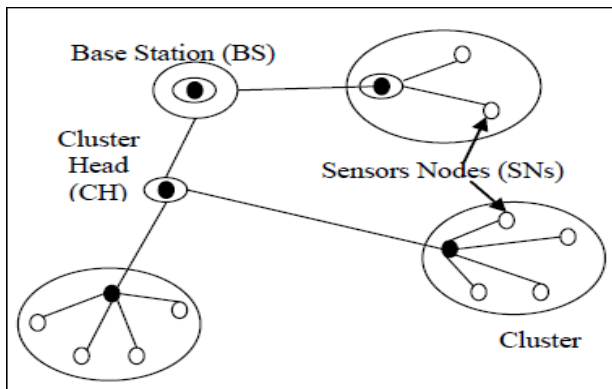

Figure.-1 Standard Model of Hierarchical Routing techniques for WSNs

In standard LEACH algorithm for the designed wireless network, from the deployed and available sensor nodes the clusters are formed based on the received signal strength. Next, the cluster heads are selected from the nodes available inside that cluster. These cluster heads (CHs) are going to serve as the routers for the deployed nodes as they enable the communication of these deployed individual sensor node to the available base station. These techniques are called to be much efficient in terms of energy consumption owing to the involvement of cluster heads are for the entire duration of transmission phase in place of the available all deployed sensor nodes. A wide range of hierarchical based routing protocol techniques have been proposed on the basis of this basic standard LEACH algorithm. PANEL [13], MODLEACH [14], HEED [15], TEEN [16], EEMC [17], PEGASIS [18], DEEC

[19] etc. are a number of trendy and the most common examples of hierarchical based routing protocol techniques. The prime objective of the researcher behind this survey paper is to talk a variety of different flavors of energy efficient hierarchical routing techniques for heterogeneous wireless sensor networks and further to compare these for set of various network parameters which enable an open area of the research work in order to continue the research in the same domain and hence develop a optimized and novel algorithm. The key focus of

researcher here is on security, reliability, throughput, and energy efficiency of the designed routing protocol for wireless sensor networks.

III. DIFFERENT HIERARCHICAL ROUTING SCHEMES

A. Low Energy Adaptive Clustering Hierarchy [12]

Low Energy Adaptive Clustering Hierarchy (LEACH) is one of the earliest and fundamental hierarchical adaptive clustering algorithms utilized in order to design the wireless sensor networks. The prime objective of this algorithm is to minimize the energy consumption and to enhance the network lifetime. This is a hierarchical clustering and routing protocol scheme which is not only adaptive but also self-organizing in nature. In order to design this clustering scheme the most vital assumption is made as the available base station is pre-assumed to be at a standstill which is positioned at an incredibly larger distance with respect to the location of the deployed sensor nodes of designed wireless network. In addition to this, the next assumption is also made as all the deployed sensor nodes of designed wireless network are considered to be homogenous in nature and equipped with extremely low and inadequate energy source. Moreover, for the designed wireless network the deployed sensor nodes are considered to be under communication not only among each other i.e. the nodes available in the surroundings but also with the nearest available base station and hence sensing the surroundings at a stagnant and non-volatile rate. The fundamental and key inspiration of LEACH algorithm is first to form the clusters within the span of the deployed nodes available in the designed wireless network and further to distribute and conclude the portions of available energy among them. Next, the selection of a unique and distinguished node is performed. This special node is better known as cluster head (CH). The primary selection of this cluster head is done based on the threshold value which is set for the designed wireless network for clusters. In order to perform the selection of cluster head (CH), each available deployed node within the cluster of designed wireless network is going to contribute after generation of a random and significant priority value ranging from 0 to 1. Furthermore, if the particular deployed sensor node is going to generate the random number value which is less than the available threshold values then that particular deployed sensor node is going to be assigned as the cluster head for that particular round. The threshold value for the particular clusters is going to be calculated by the extensive use of Equation 1.

$$T_n = \begin{cases} \frac{p}{1 - p * r \bmod \frac{1}{p}}, & n \in C \\ 0, & \text{Else} \end{cases} \quad (1)$$

Where, p is the probability of any particular deployed sensor node to be assigned as cluster head, r is the number of the rounds executed for the current round and C is the entire collection of deployed sensor nodes with the exclusion of the cluster head in preceding rounds (only these sensor nodes are going to have the eligibility of being assigned as cluster head for existing ongoing round or upcoming rounds). As soon as all the rounds are concluded, the final threshold value T_n is going to attain the value as unity. As a result, all the available deployed nodes within the particular ongoing cluster become eligible to be assigned as cluster head all over again. Hence, we can conclude that the

LEACH is an absolutely distributed, hierarchical and adaptive routing protocol.

Reduction in energy consumption i.e. extremely energy efficient, higher throughput rates, improved and superior network lifetime, superior battery lifetime as a result of the nominal and minimal collisions inside the particular cluster etc. are a number of advantages of LEACH algorithm. On the other hand, additional amount of energy consumption due to augmented ongoing communication with the particular cluster and tainted network lifetime during the selection of a cluster head which is a deployed sensor node with lower energy value owing to the dynamicity of cluster head location data are some shortcomings of usage of LEACH algorithm. In addition to this for multi hop communication, the designed LEACH routing protocol scheme is not found to be reasonable. This is mainly because of irregular and non-uniform energy dissipation among the deployed sensor nodes which are at extremely adjacent location and are extremely farthest away with respect to the location of base station over the particular cluster for designed wireless network. In addition to this, the dynamic clustering scheme also serves as an additional superfluous overhead issue. Along with these discussed issues, assumptions made for implementing the LEACH algorithm such as static cluster structure, initialization of the deployed sensor nodes with similar value of energy, etc. additionally formulate the inroads in order to improve and optimize the traditional LEACH algorithm.

B. Hybrid Energy-Efficient Distributed Clustering [15]

Hybrid Energy-Efficient Distributed clustering (HEED) is going to select the cluster heads periodically in accordance with a hybrid of both the residual energy of deployed node along with a secondary parameter, such as node proximity to the neighborhood sensor nodes or node degree. This technique is going to get terminated in $O(1)$ iterations. In addition to this, HEED algorithm is subjected to very less message overhead and is going to attain reasonably homogeneous and standardized distribution for cluster head throughout the entire network. Furthermore this algorithm proves out to be putting suitable constraints on both inter and intra cluster communication range along with the node density.

Hence, this algorithm asymptotically approximately indubitably gives assurance for the continuous connectivity of designed clustered wireless networks. Simulation results demonstrated that this implemented approach was effective in terms of enhanced network lifetime and throughput along with the superior support for scalable data aggregation. Furthermore, this clustering technique was found to obtain a very well connected inter-cluster wireless network with multi hop communication along with both precisely specified density model and a specified and unique relationship between cluster range and transmission range hold.

C. Threshold Sensitive Energy Efficient Sensor Network protocol [16]

Threshold Sensitive Energy Efficient Sensor Network protocol (TEEN) hierarchical routing protocol technique is mainly designed for both to provide quick response and to sense the attributes immediately. This technique is going to be very much useful in real time critical applications such as trespasser and detection of explosives. Data centric methodology in conjunction with the hierarchical approach is going to be

incorporated comprehensively with the intention of design this routing protocol scheme. This technique is also another conservatory flavor of basic LEACH algorithm. The only significant differentiation is for the duration of data transmission which is going to happen from cluster head (CH) to the respective base station. In this technique in preference to sending data straightforwardly from cluster head to base station, rather the data is going to be sent from subordinate level cluster head to next superior level cluster head which is up in hierarchical ladder and is going to be set aside on transmitting amongst inter level cluster heads and lastly going to be transmitted to the respective base station. In addition to this in place of single threshold, two unlike threshold values soft threshold and hard threshold are going to be used. The soft threshold is going to be utilized in order to shrivel the volume of transmissions on every occasion in case there is trivial or no divergence in the sensing trait. While the hard threshold is going to be utilized to shrivel the volume of transmissions with the permissions given to deployed sensor nodes to transmit the data only to the sensing nodes available in the range of region of interest. Besides all this, the data is also going to get accelerated from the respective deployed sensor node in the current ongoing round only if the available sensor node is having the threshold value greater than the hard threshold value along with the available sensor node threshold value being altered from the value available in last round by an amount greater than or equal to soft threshold value.

D. Power Efficient Gathering in Sensor Information Systems [18]

Power Efficient Gathering in Sensor Information Systems (PEGASIS) is a unique sequential or chain structured hierarchical routing protocol used to design wireless networks. This is also an enhanced or improvised version of standard LEACH algorithm which is going to provide better network lifetime for the designed wireless sensor network. Analogous to the basic LEACH algorithm, in this algorithm first the sensor nodes are deployed randomly in the given network area. The communication is different here than the standard LEACH algorithm. The deployed sensor nodes are going to transmit the information to the other available sensor nodes which are in the closest proximity or neighborhood for that particular node with appropriate adjustments in transmission power available. The distance among the particular sensor node and the neighborhood deployed sensor nodes is going to get calculated on account of the available signal strength. By using this methodology, the entire sensor nodes are connection in a chain fashion with the extensive use of Greedy Algorithm and finally only one node is going to be connected to the available base station which is in the adjoining closest proximity of base station. Furthermore, at random a node is going to be selected as cluster head (CH) in order to complete the transmission of data or information in the midst of the sensor nodes and base station. This technique is further going to lower not only the overhead related issues but also the bandwidth related constraints from the available base station. Consequently, the individual deployed sensor node is going to be responsible for the transmission and hence the receipt of only single and unique packet in each and individual round and at least once will be going to get selected as cluster head (CH) in „n” number of rounds where „n” designates the deployed number of nodes in designed wireless sensor network.

E. Distributed Energy Efficient Clustering protocol [19]

In Distributed Energy Efficient Clustering (DEEC) hierarchical routing protocol technique the cluster heads (CHs) are going to get selected in a unique manner. In place of getting selected based on the standard threshold value, the cluster heads are going to be selected based on a generic probability equation. In this case, the probability value is illustrated as ratio of the residual energy for each of the deployed sensor node and the average energy for the given designed wireless network. Consequently as a result of these different types of residual and initial energy, the rotational iteration for given individual deployed sensor node is also unique in nature. Additionally, the selection of the cluster head is also exclusively based on the residual and initial energy of the sensor nodes. Due to this, as long as higher the residual and initial energy of the sensor node is going to result in higher probability of going to get selected as cluster head for that particular node. Consequently, DEEC based hierarchical clustering protocol technique is going to provide the improvised network lifetime which further going to enable the stability in period. This routing technique is also utilize the concept of average energy of the designed wireless sensor network as the reference energy with the wide-ranging application of adaptive methodologies with the intention of bearing out and controlling the entire energy costs for the deployed sensor nodes in designed wireless network. As a result, this routing protocol scheme is not requiring any type of universal information regarding the available energy on the deployed sensor node even after completion of every cluster head selection round. Furthermore, this technique facilitates us in order to design and develop a multi-level heterogeneous wireless sensor network and then performing the data transmission over the designed network.

F. Energy Efficient LEACH [20]

Energy efficient LEACH (EE LEACH routing protocol methodology was proposed in order to prevail over the concerns of single hop communication and capricious technique of selection of cluster head in basic LEACH algorithm. With the intention of accumulation of substantial energy consumption, a proficient and well organized data aggregation and the largest part of complimentary cluster formation this technique was found to be a sanguine and ultimate resolution. The fundamental theorem of conditional probability is going to be incorporated in order to achieve an efficient and organized data aggregation. Furthermore, the Gaussian distribution scheme is also incorporated with the purpose of achieving the superior and enhanced coverage of designed wireless network. Although, the residual energy of neighborhood nodes is going to enable the developer in order to outline the most favorable cluster. This desired optimal probability which is going to be used for selection of cluster head is generally observed as to be function of spatial density. Furthermore, this is going to enable us to improvise the reliability and the consistency for the entire duration of data transmission, data rates, throughput, and network lifetime. In addition to this, to carry out the eminence and unambiguous data transmission from the deployed nodes to the respective base station, selection of the highest residual energy nodes is done in order to achieve the energy efficiency. The issue with this technique is augmented complexity and paucity in terms of both scalability and data integrity.

G. Energy Harvested Aware LEACH [21]

Energy Harvested Aware LEACH hierarchical routing algorithm is going to make use of the nodes which are harvested in terms of energy with the intentions of improvising the performance of basic LEACH algorithm. In this technique, the optimization schemes were evolved. The key objective function for this technique was to capitalize on the least conserved energy for each and individual deployed sensor node in designed wireless network. As a result, this scheme is derived from the concepts of solving a max-min state of affairs. The selection of cluster head in this technique is generally going to be done based on both energy consumption and energy harvesting capacity. Hence any deployed sensor node which is going to attain the lowest energy consumption along with attaining the highest energy harvesting capacity is serving for the highest probability to be selected as the cluster head. This enables an enrichment and augmentation over the basic LEACH algorithm. In view of the fact that the proposed technique is going to make use of the feature of sensor nodes with energy harvesting and due to rate of energy consumption, Energy Harvested Aware LEACH is going to take over the standard LEACH in the lieu of all the characteristics such as energy consumption and network lifetime etc. The only matters of concerns with this scheme are higher cost of designs along with the increased complexity.

H. Medium Access Control LEACH [22]

There are various flavors of LEACH algorithms which are available. But most of these are found to be using random, distributed and dynamic techniques in order to perform the clustering. These techniques are not going to supply the superlative and ultimate number of clusters within the designed wireless network. Medium Access Control based LEACH (MAC LEACH) hierarchical routing algorithm is going to place a constraint over the number of cluster heads which are going to get selected underneath the advertisement in order to alleviate the issue of randomness. As a result, the superlative and ultimate numbers of cluster heads are achieved. Throughout the selection of cluster head, every time a dynamic cluster head group variable is getting initialization with the zero as initial value and is further added with unity if it has ability to accept the message of cluster head advertisement. If the value of this dynamic cluster head group variable is found to be less than the superlative and ultimate number of clusters, it is going to get declared as cluster head and it is going to transmit a cluster head advertisement else it will be going to get considered as an ordinary or simple deployed sensor node. This routing protocol offers superior network lifetime as compare to standard LEACH algorithm. However, message overheads and design complexity are two foremost apprehensions of this scheme.

I. Orphan LEACH [23]

Orphan LEACH (O-LEACH) hierarchical routing scheme was proposed in order to smoothen the progress of superior connectivity rate at the same time as covering the vast area of wireless network. In this scheme, the nodes which are not under regulation of any cluster head are designated as orphan nodes. This routing scheme is discussed for two different types of situations. In first case, orphan nodes within a cluster are regulated and find a gateway using one of the deployed nodes within the same cluster. Gateway node is further joined by the corresponding orphan nodes and their data is going to be transmitted to this gateway. In addition to this, the available data is well aggregated and then transmitted to the base station similar to cluster head via single hop communication. However in

second case, orphan nodes are defined as the nodes which are existing inside any uncovered region of wireless network. Furthermore, these nodes are going to form another cluster and a cluster head is selected inside this cluster only on the basis of the minimal distance to the available gateway nodes. Next, the selected cluster head collects the data from the nodes available in this cluster and transmits to gateway nodes after aggregation. This routing scheme is going to enable us for superior connectivity rate, scalability, energy efficiency and improvised coverage area as compared to standard LEACH algorithm. The key concerns for this technique were in searching and locating the orphan nodes and then collection of their respective information. In addition to this, delayed data delivery and control overhead are also going to set supplementary restrictions on this routing technique.

J. Cross Layer LEACH [24]

In order to improve the network lifetime, cross layer LEACH (CL-LEACH) hierarchical routing algorithm was proposed with manipulation of cross layer techniques. There are four basic steps involved in this technique namely –

- Formation of cluster
- Establish the routing for communication
- Perform the Cross Layer Leach algorithm
- Maintenance of the routing

During formation of cluster, first the cluster heads are selected among the deployed nodes within the cluster. Selection of cluster head is done on the basis of their distance from the base station and residual energy. In second step of routing the process is performed in two steps. First the routes are discovered and then the distance is calculated for them. The distance is calculated with the help of standard distance formula from mathematics of coordinate geometry. In this scheme threshold value and residual energy for the deployed node is input. For multi hop communication the relay node is configured, which is defined as the node which is having its residual energy greater than the threshold value. Maintenance of routing discovers the damaged links in addition to both source and destination nodes. These broken paths are replaced by other available new paths in available routing in order to provide maintenance to them. This routing technique was going to provide the evidences of being energy efficient and enabling the enhanced network lifetime as compared to the basic LEACH algorithm. However, message overheads and design complexity are two foremost apprehensions of this scheme.

IV.COMPARISON OF DIFFERENT ENERGY EFFICIENT ROUTING TECHNIQUES

Table-I presents a comparative analysis of various versions of LEACH discussed and surveyed in this paper by the researcher. The prime objective for methodology involved in selection of cluster head and then functionality for discussed protocols along with their pros and cons are listed in this table. However, the selection of the routing protocol technique also depends on the choice of network performance parameters such as cluster formation, selection of cluster head, energy efficiency, scalability, throughput, cost effectiveness, network lifetime, mobility, network and algorithm complexity etc.

Table I. Comparison of different energy efficient routing techniques

Routing Scheme	Description	Advantages	Disadvantages
LEACH [11]	CH selection is done using threshold based probability. Single hop communication and used for homogeneous networks.	Delay is less Low complexity Cost effective	Poor scalability Not energy efficient Moderated stability and load balancing Poor lifetime
HEED [15]	CH selection is done periodically with a hybrid of residual energy and a secondary parameter, such as node degree or proximity to the neighborhood nodes.	Better lifetime Better throughput Aggregation of data is good	High complexity Moderated energy efficiency Overhead issue
TEEN [16]	Data is sent from lower level cluster head to next level cluster head. Works on soft and hard threshold.	Very good lifetime Energy efficiency is good High stability	High complexity Poor scalability Calculation of dual threshold
PEGASIS [18]	CH selection is done randomly. Single hop communication with multi level hierarchy and used for homogeneous networks.	Good lifetime Moderated energy efficiency	Delay is large Low stability High complexity Moderated load balancing
DEEC [19]	Cluster head is selected by ratio of residual and average energy. Works in multi level heterogeneous networks.	High stability Better lifetime Lower complexity	Moderated energy efficiency Advanced nodes die rapidly
EE-LEACH [20]	Conditional probability and use of Gaussian distribution scheme. Spatial density is useful for CH selection.	Energy efficiency is good Better lifetime High data rates	High overhead and complexity Low data integrity
EHA-LEACH [21]	Maximizing the minimum conserved energy. CH Selection is based on energy consumption and energy harvesting capacity.	Energy efficiency is very high Good load balance High throughput	Very high overhead and complexity Higher cost
MAC-LEACH [22]	Puts a restriction over number of cluster heads getting selected under CH advertisement.	Energy efficiency is very high Good load balance High throughput	High overhead and complexity
O-LEACH [23]	Nodes which are not under regulation of any cluster head are named as orphan nodes.	Energy efficiency is very high Good load balance Better coverage	High overhead and complexity Less throughput
CL-LEACH [24]	Threshold value and residual energy for the deployed node is input. Uses relay nodes.	Energy efficiency is very high Good load balance Better lifetime	High overhead and complexity Poor data rates Less throughput

REFERENCES

- [1] A. Abed, A. Alkhatib, and G. S. Baicher, "Wireless sensor network architecture," in International Conference on Computer Networks and Communication Systems (CNCS 2012), vol. 35. Singapore: IACSIT Press, 2012, pp. 11–15.
- [2] S. Pino-Povedano, R. Arroyo-Valles, and J. Cid-Sueiro, "Selective forwarding for energy-efficient target tracking in sensor networks," *Signal Processing*, vol. 94, pp. 557–569, 2014.
- [3] R. Govindan, J. Heidemann, S. Kumar, and D. Estrin, "Next century challenges: scalable coordination in sensor networks," in ACM/IEEE International Conference on Mobile Computing and Networking, New York, NY, USA, 1999, pp. 263-270.
- [4] I. F. Akyildiz, W. Su, Y. Sankarasubramaniam, and E. Cayirci, "Wireless sensor networks: A survey," *Computer Network*, vol. 38, no. 4, pp. 393–422, Mar. 2002.
- [5] N. Javaid, A. Rahim, U. Nazir, A. Bibi, Z. A. Khan, and M. S. Aslam, "Survey of extended leach-based clustering routing protocols for wireless sensor networks," in Proc. IEEE 14th International Conference on High Performance Computing and Communication & IEEE 9th International Conference on Embedded Software and Systems, 2012, pp. 1232-1238.
- [6] Z. Zhang and V. Varadharajan, "Wireless Sensor Network key management survey and taxonomy," *Journal of Network and Computer Applications*, vol. 33, pp 63-75, 2010.
- [7] N. A. Pantazis, S. A. Nikolidakis, and D. D. Vergados, "Energy efficient routing protocols in wireless sensor networks: A survey," *IEEE Communications Surveys Tutorials*, vol. 15, no. 2, pp. 551–591, Second 2013.
- [8] Z. J. Haas, J. Y. Halpern, and L. Li, "Gossip-based ad hoc routing," *IEEE/ACM Trans. Netw.*, vol. 14, no. 3, pp. 479–491, Jun. 2006.
- [9] J. Kulik, W. Heinzelman, and H. Balakrishnan, "Negotiation based protocols for disseminating information in wireless sensor networks," *Wireless Networks*, vol. 8, no. 2, pp. 169–185, 2002.
- [10] C. Intanagonwiwat, R. Govindan, D. Estrin, J. Heidemann, and F. Silva, "Directed diffusion for wireless sensor networking," *IEEE/ACM Trans. Netw.*, vol. 11, no. 1, pp. 2–16, Feb. 2003.
- [11] D. Braginsky and D. Estrin, "Rumor routing algorithm for sensor networks," in Proceedings of the 1st ACM International Workshop on Wireless Sensor Networks and Applications, ser. WSNA '02. New York, NY, USA: ACM, 2002, pp. 22–31.
- [12] W. Heinzelman, A. Chandrakasan, and H. Balakrishnan, "Energy-efficient communication protocol for wireless micro sensor networks," in System Sciences, 2000. Proceedings of the 33rd Annual Hawaii International Conference on, Jan 2000, p. 10 vol.2.
- [13] L. Buttyan and P. Schaffer, "PANEL: Position-based aggregator node election in wireless sensor networks," in 2007 IEEE International Conference on Mobile Adhoc and Sensor Systems, Oct 2007, pp. 1–9.
- [14] D. Mahmood, N. Javaid, S. Mahmood, S. Qureshi, A. M. Memon, and T. Zaman, "MODLEACH: A variant of leach for WSNs," in Broadband and Wireless Computing, Communication and Applications (BWCCA), 2013 Eighth International Conference on, Oct 2013, pp. 158–163.

AUTHOR'S BIOGRAPHY

First Author: Ramana Boina Kalyani, M.Tech, Assistant Professor



Working as Assistant professor in ECE department, published Four international paper publications.

Second Author: Dhanika Srinivas, M.Tech Assistant Professor



Working as Assistant professor in ECE department, published three international paper publications