

IoT-BASED MOBILE APPLICATION FOR MONITORING OF HYDROPONIC VERTICAL FARMING

Varraa Shivija^{1*}, Peerzada Mahabooba^{2*}, Tanguturu Mamatha^{3*}, Gopi Reddy Ganesh Reddy^{4*}, Kandhukuri Nagateja^{5*} and V. Mahesh Kumar Reddy^{6*}

^{1,2,3,4,5}UG Student, Electrical and Electronics Engineering, Chaitanya Bharathi Institute of Technology, Proddatur, India, 516360

⁶Head of the International relations of CBIT, Professor, Electrical and Electronics Engineering, Chaitanya Bharathi Institute of Technology, Proddatur, India, 516360

Corresponding email: varrashivija@gmail.com

Abstract: From October 2023 Society Hunt Machine Optimization Rapid growth in populations has increased pressure on available pastoralist land and traditional styles of husbandry. Large increases in population have redounded in new issues facing the product of food, similar as changing patterns of climate, reduced vacuity of fresh water, adding demand for food, and loss of biodiversity. These types of challenges pose a significant threat to global food security. This paper describes a mobile Android operation that can autonomously cover and manage factory growth in a hydroponic inner perpendicular husbandry terrain. Environment and nutrient variables collected from specific detectors similar as ambient temperature, relative moisture, total dissolved solids (TDS), pH, and water situations as well as light intensity will shoot data to the ThingSpeak pall. The Tashi Home Pindfresh perpendicular husbandry unit will act as the testbed, and its primary regulator will correspond of an Arduino Mega and jeeb Pi tackle objects.

I. INTRODUCTION

According to population estimates, humans will exceed 9 billion in 2050. This protuberance places numerous individualities in civic areas which bear a larger food force (a projected 70 further) than can be produced by current husbandry due to the frequency of dropped vacuity of cropland through climate change and times of ferocious husbandry practices. Judges believe that a reduction of 10 in available pastoralist land will do by 2050 performing in increased demand for food that cannot be met by traditional husbandry.

Vertical husbandry is a feasible system for crop product that allows for multiple crops to be produced at the same time from an inner terrain. Greater yields can be achieved per square bottom of growing space; crops can be gathered no matter what the rainfall is like outdoors because perpendicular granges operate in enclosed surroundings and have controlled surroundings. By exercising hydroponics, aeroponics and aquaponics (styles to grow shops without soil), shops admit nutrients through water, which makes growing outdoors much further resource effective than traditional husbandry. The advancement of IoT technologies has created strong openings to give real-time dimension and control of husbandry using automated systems. For case, experimenters have developed IoT-grounded hydroponic systems, including one developed using ThingSpeak to control pH, fish feeding, temperature, and light for growing Romaine lettuce and demonstrated significantly better results than traditional growing. Another IoT-grounded hydroponic system was erected using an ESP32 device and the Ubidots platform that used fuzzy sense control to maintain optimal conditions for growing rice, lettuce, and basil.

Objectives

Inner crop civilization demands nonstop alert and precise parameter control. counting purely on homemade observation introduces mortal error and delayed responses to changing conditions. Automated IoT results overcome these limitations by delivering real-time data through mobile and web interfaces, allowing farmers to act fleetly without being physically present. The exploration objects addressed in this work are Design and make a completely automated perpendicular husbandry structure able of supporting nonstop growth of Romaine Lettuce. Integrate technologies to allow the system to tone-regulate critical growth parameters including automatic LED scheduling, pH and TDS balancing, and water-position conservation. Connect the physical husbandry tackle to an IoT pall platform and present all captured data through an intuitive mobile operation.

Existing Methods

Prior to the preface of IoT-enabled robotization, perpendicular granges and hydroponic systems employed traditional, labor-ferocious means of covering their inner agri-systems. therefore, it's critical to understand the scarcities essential in these previous styles of covering growing parameters in order to completely understand the benefits deduced from enforcing the proposed results.

Homemade Monitoring And Parameter Control

In the history, traditional perpendicular husbandry interpreters reckoned on their ranch staff to performed-scheduled, on-point examinations to measure and record every critical factory growth parameter. The most generally used system to measure humidity was to convert the ranch platoon's hand into a "humidity cadence". In other words, ranch staff regularly checked soil humidity by pushing their outlet into the soil (with their drive against the soil

representing the humidity position). also, farmers tested their pH and TDS situations using movable pH and TDS measures.

likewise, traditional growers measured temperature and moisture using stage-alone instruments (e.g. thermometers hygrometers). Since there's no system of nonstop data collection, flash diversions (similar as unforeseen drops in pH and peaks in temperature) could go undetected for hours before any action was taken to remedy the effect on crop health.

Limitations of Traditional styles

- High Labour Intensity Frequent homemade examinations performed on multiple situations of perpendicular granges bear significant mortal coffers to perform examinations — latterly adding operating costs as well as creating difficulties when trying to deliver large- scale results.
- Delay in Responding to Parameter dissonances Without nonstop real- time data collection, both pH and nutrient attention, and ambient temperature dissonances will go undetected between examination dates. thus, if a crop gests stress due to either or any of these three parameters, it'll not be entered into a posterior test for over to 12 hours — or until the coming examination takes place — therefore having the eventuality to reduce crop yield.

Inefficient Resource operation Due to the reliance upon fixed- interval scheduling for irrigation and nutrient additions, perpendicular granges constantly moreover over- or under- cure, thereby wasting both nutrients and water.

Suggested System Design

Overview of System Design Architecture

As depicted in Figure 1, the overall IoT armature for this design connects the detectors through the Arduino Mega regulator to the Raspberry Pi gateway, which also relays data via Wi- Fi to the pall- grounded IoT platform, ThingSpeak. In addition, mobile druggies can also request readings through the peaceful API that ThingSpeak provides a system to recoup. Selectors (pump, LEDs, faucets) are commanded back through the same circle to produce an unrestricted circle feedback control system between all bias.

B. Vertical Farming Infrastructure

The physical perpendicular husbandry system is grounded on a three- position or tiered hydroponic unit from Pindfresh Tashi Home, which is constructed with three perpendicular categories that form an open frame that's vertically piled in which each league contains three civilization tubes; therefore, having an aggregate of nine tillers for all categories. There are an aggregate of 81 possible planting positions available at formerly for all categories within the rack. The perpendicular husbandry unit is designed to operate using a hydroponic growing system appertained to as a Deep Flow fashion(DFT), where shops are suspended over the root zone in shallow channels of continuously flowing nutrient result. The result is circulated by a devoted nutrient force and water pump for the entire system across all three categories.

C. Controlled Environment & Sensor Suite

An extensive array of sensors is integrated into this system, all interfaced with the Arduino Mega acting as the CPU/controller:

Parameter	Recommended Range
pH Level	5.5 – 6.5
TDS	560 – 840 ppm
Temperature	20°C – 25°C
Humidity	40% – 70%

Table 1: Ideal Growth Parameter Ranges for Romaine Lettuce

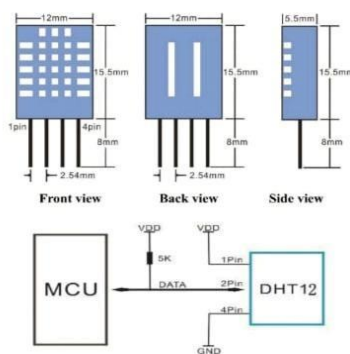

Block diagram:

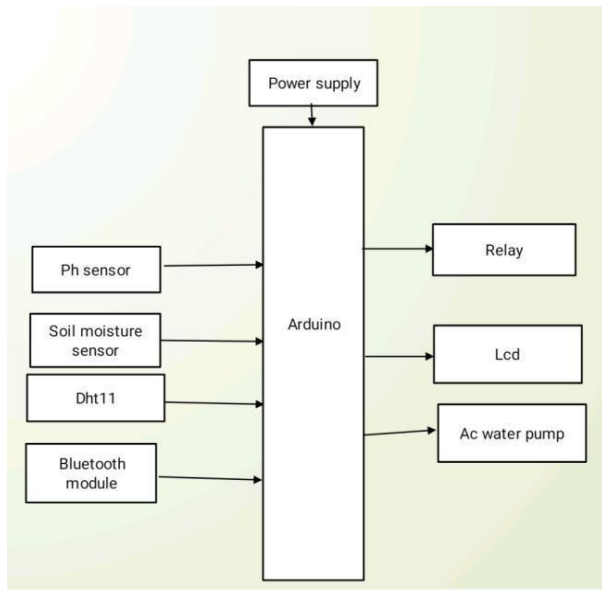

Fig :- Block Diagram

Application Development

A. Integration via ThingSpeak

The linking of the physical sensor array to the digital stoner interface necessitates a reliable pall reconciler. In this particular arrangement, the ThingSpeak IoT logical platform fulfills the role by consuming sensor readings from the Arduino regulator, storing the data in channel-

		Climate Fragment (Temp/Hm/Light)	Nutrition Fragment (pH/TDS low)	Image Fragment (WebCam)
--	--	----------------------------------	---------------------------------	-------------------------

based aqueducts, and allowing the data to be queried remotely through peaceful API calls. This block diagram gives us the data access to become removed from donation sub caste.It make sure that mobile operation allows least data irrespective of stoners location(physical)

Physical Environment (Farm)	→	Sensor Data Acquisition	→	Arduino Processing Control	→	Cloud Storage (ThingSpeak)	→	User Dashboard (Mobile)
-----------------------------	---	-------------------------	---	----------------------------	---	----------------------------	---	-------------------------

A. Verti Farm Control Android Application

The mobile interface — named VertiFarmControl was developed using Android Studio, the sanctioned IDE for Android operations. The codebase combines Java for operation sense, XML for stoner interface layouts, and JSON as the data exchange format between the pall and the device. The HTTP Volley networking library handles all API requests

and response parsing, delivering detector data efficiently to on- screen factors.

The operation's stoner trip begins with a five-alternate Splash Screen before turning to authentication. Google subscribe- In through Firebase provides secure account operation each stoner receives a unique identifier(UID) and their profile details are stored in Firebase's real- time database, icing husbandry data is accessible only to authorised individualitie.

Launch Screen (5 sec)	→	Login Screen (Google Auth)	→	Main Screen (3 Fragments)
-----------------------	---	----------------------------	---	---------------------------

III.Application Interface

Main screen is divided into re dedicated parts of plant liveliness These partitions fragments combines environment variables together and provide live data of temperature,relative humidity and,light intenity and toxic gass position. With the help of screen understand the changes in plant. According to climatic changes and growth of the plant. Range of temperature id 25.9 o light intensity 519.2 lux. It shows parameters like TDS readings in corridor per million and pH value is 5.78, water position is 100 The image captured by webcam deposited on husbandry track. It reflects boxes bounce and measurable dimensions or overlay on images. It gives plant growth and progress without physical examination. It helps visual verification of plant,health and stage of growth.

Fragment	Key Metri Displayed	Purpose
Climate	Temperature, Humidity, Luminous Intensity	Overview environmental condition
Nutrition	pH Level, Wat Level %, Flow Status, TDS (ppm)	Solution chemistry nutrient level
Images	Live annotat webcam phot with size overlay	Tracking of Visu growth

Results and Data Analysis

ROMAIN LETTUCE ANALYSIS TIME SERIES DATA ON TEMPERATURE, PH, TDS, HUMIDITY WATER LEVELS, LIGHT INTENSITY.

Parameter	Observed Range	Optimal Range	Status / Note
Temperature	27°C → >30°	20°C – 25°C	Exceeded ceiling; m0bi alerts triggere
Humidity	65% – 85%	40% – 70%	Occasionally below Optima
TDS	560-1000 ppm	560-840 ppm	Spikes to 100 ppm next nutrient top-u

pH	5.0-6.5	5.5-6.5	Gradual decline corrective action require
Water level	~89%-100%	Maintain $\pm 90\%$	Auto top-up mechanism confirmed effective
Light Intensity	0-1000+ lux	Controlled cycle	LED scheduling accepted by sensor cycling

Table 3: Important Sensor Observations vs. level Growth Parameter Ranges

Among others, some key compliance issues are that the temperature increased constantly from around 27 °C to more than 30 °C, sometimes surpassing the ideal 25 °C limit for Romaine Lettuce and triggering alerts in the mobile app. The moisture levels fluctuated between 65 – 85%, sometimes falling below the ideal moisture level conditions. The TDS figures were astronomical between 560 – 840 ppm, although there were sporadic cases when these figures rose to 1000 ppm after nutrient top-ups. The pH levels gradually fell from 6.5 to 5.0 through time, requiring interventions. Water level measurements indicated that the automated water supply system retained sufficient capacity just like in previous instances, while the light intensity showed well-controlled cycles according to the LED system's timings.

It is evident that the combined IoT device is capable of capturing fine-tuned variations in environmental parameters and transmitting them instantly to the mobile app. Consequently, appropriate actions can be taken to adjust conditions, without any major hassle. In addition, the constant stream of data can prove invaluable in adjusting the threshold parameters in subsequent repetitions.

II. Conclusion and Future Directions

Increasing agrarian land, the demand for scalable and technology driven styles for producing food has now way been lesser. This exploration presents a complete Internet of effects (IoT) result that Due to the combined goods of a growing global population and decomposes a detector-grounded hydroponic perpendicular ranch with a pall connected Android operation in order to give real-time factory monitoring ever.

The VertiFarmControl platform has demonstrated that all important growth parameters can be covered without mortal intervention temperature, moisture, pH, Total Dissolved Solids (TDS), water position, light position, gas toxin, and water inflow; and provides real-time visual feedback from the erected- in videotape cameras. By barring utmost of the need for mortal involvement, the system supports Sustainable Development thing (SDG) Number 2 (Zero Hunger) and will grease effective and reliable food product in civic surroundings.

- Development of artificial intelligence (AI) grounded premonitory features in the operation which will give

guidance for optimal crop product grounded on detector readings, alert patterns, and technical knowledge bases.

- Expansion of the platform for multiple contemporaneous units for larger scale product.
- The use of machine literacy to develop models to descry complaint early via image analysis; this opens substantial exploration avenues for reducing crop losses.

References

- [1] United Nations Department of Economic and Social Affairs, World Population Prospects 2019. New York, USA: United Nations, 2019.
- [2] Food and Agriculture Organization of the United Nations, The Future of Food and Agriculture. Rome, Italy: FAO, 2017.
- [3] A. Ragaveena, A. Edward Shirly, and U. Surendran, "Smart controlled environment agriculture methods: A holistic review," *Reviews in Environmental Science and Bio/Technology*, vol. 20, pp. 887–913, 2021.
- [4] D. Shamshiri et al., "Research and development priorities for indoor vertical farming: Growing technologies, harvesting, and automation," *International Journal of Agricultural and Biological Engineering*, vol. 11, no. 3, pp. 1–22, 2018.
- [5] K. Al-Kodmany, "The vertical farm: A review of developments and implications for the vertical city," *Buildings*, vol. 8, no. 2, p. 24, 2018.
- [6] T. Avgoustaki and G. Xydis, "Indoor plant factories in the urban landscape and their role in food production," *Foods*, vol. 9, no. 9, p. 1270, 2020.
- [7] S. Saaid, N. A. Yahya, M. Fadhil, and M. Ali, "Automatic microcontroller system for indoor hydroponic NFT plant," in *Proceedings of the IEEE 3rd International Conference on System Engineering and Technology*, 2013, pp. –.
- [8] Z. Md. Ali et al., "IoT based smart greenhouse monitoring system," *International Journal of Advanced Computer Science and Applications*, vol. 9, no. 8, 2018.
- [9] M. S. Asnarni Ludin, P. Prarthana, and A. P. Ismail, "IoT-based smart hydroponics management system," *International Journal of Sustainable Agricultural Management and Informatics*, vol. 4, no. 3–4, pp. –, Year.