

Mitigation of the Wind Generation Integration Related Power Quality Issues by Energy Storage

*P.Raja Sekhar¹,Assistant Professor,Dept of EEE,rajaeee235@gmail.com,SVPCET,Puttur
S.VenkatRao²,Asst .Professor,Dept of EEE,venkatrao0254@gmail.com,SVPCET,Puttur*

Abstract: Injection of the wind power into an electric grid affects the power quality. The performance of the wind turbine and thereby power quality are determined on the basis of measurements and the norms followed according to the guideline specified in International Electro-technical Commission standard,IEC-61400. The influence of the wind turbine in the grid system concerning the power quality measurements are-the active power, reactive power, variation of voltage, flicker, harmonics ,and electrical behavior of switching operation and these are measured according to national/international guidelines. The paper study demonstrates the power quality problem due to installation of wind turbine with the grid. In this proposed scheme STATic COMPensator (STATCOM) is connected at a point of common coupling with a battery energy storage system (BESS) to mitigate the power quality issues. The battery energy storage is integrated to sustain the real power source under fluctuating wind power. The STATCOM control scheme for the grid connected wind energy generation system for power quality improvement is simulated using MATLAB/SIMULINK in power system blockset. The effectiveness of the proposed scheme relieves the main supply source from the reactive power demand of the load and the induction generator. The development of the grid co-ordination rule and the scheme for improvement in power quality norms as per IEC-standard on the grid has been presented

I. INTRODUCTION

TO have sustainable growth and social progress, it is necessary to meet the energy need by utilizing the renewable energy resources like wind, biomass, hydro, co-generation,etc In sustainable energy system, energy conservation and the use of renewable source are the key paradigm. The need to integrate the renewable energy like wind energy into power system is to make it possible to minimize the environmental impact on conventional plant [1]. There has been an extensive growth and quick development in the exploitation of wind energy in recent years. The individual units can be of large capacity up to 2 MW, feeding into distribution network, particularly with customers connected in close proximity.Today, more than 28,000 wind all the fluctuation in the wind speed are transmitted as fluctuations in the mechanical torque, electrical power on the grid and leads to large voltage fluctuations. During the normal operation, wind turbine produces a continuous variable output power. These power variations are mainly caused by the effect of turbulence, wind shear, and tower-shadow and of control system in the power system. Thus, the network needs to manage for such fluctuations. The power quality issues can be viewed with respect to the wind generation, transmission and distribution network, such as voltage sag, swells, flickers,harmonics etc. However the wind generator .Introduces disturbances into the distribution network. One of the simple methods of running a wind generating system is to use the induction generatorConnected directly to the grid system. The induction generator has inherent advantages of cost effectiveness and robustness. However; induction generators require reactive power for magnetization. When the

generated active power of an induction.Generator is varied due to wind, absorbed reactive power and terminal voltage of an induction generator can be significantly affected. A proper control scheme in wind energy generational operating condition to allow the proper control over the active power production. In the event of increasing grid disturbance, a battery energy storage system for wind energy generating system is generally required to compensate the fluctuation generated by wind turbine. A STATCOM based Control technology has been proposed for improving the power quality which can technically manages the power level associates with the commercial wind turbines. The proposed STATCOM control scheme for grid connected wind energy generation for power quality improvement has following objectives.

- Unity power factor at the source side.
- Reactive power support only from STATCOM to wind Generator and Load.
- Simple bang-bang controller for STATCOM to achieve fast dynamic response.

The paper is organized as follows. The Section II introduces the power quality standards, issues and its consequences of wind turbine. The Section III introduces the grid coordination rule for grid quality limits.

II. POWER QUALITY STANDARDS, ISSUES AND ITS CONSEQUENCES

A. International Electro Technical Commission Guidelines
The guidelines are provided for measurement of power quality of wind turbine. The International standards are developed by the working group of Technical Committee-88 of the International Electro-technical Commission (IEC),

IEC standard 61400-21, describes the procedure for determining the power quality characteristics of the wind turbine [4].The standard norms are specified.

- 1) IEC 61400-21: Wind turbine generating system, part-21. Measurement and Assessment of power quality characteristic of grid connected wind turbine
- 2) IEC 61400-13: Wind Turbine—measuring procedure in determining the power behavior.
- 3) IEC 61400-3-7: Assessment of emission limit for fluctuating load IEC 61400-12: Wind Turbine performance.The data sheet with electrical characteristic of wind turbine provides the base for the utility assessment regarding a grid connection.

B. Voltage Variation

The voltage variation issue results from the wind velocity and generator torque. The voltage variation is directly related to real and reactive power variations. The voltage variation is commonly classified as under:

- Voltage Sag/Voltage Dips.
- Voltage Swells.
- Short Interruptions.
- Long duration voltage variation.

The voltage flicker issue describes dynamic variations in the network caused by wind turbine or by varying loads. Thus the power fluctuation from wind turbine occurs during continuous operation. The amplitude of voltage fluctuation depends on grid strength, network impedance, and phase-angle and power factor of the wind turbines. It is defined as a fluctuation of voltage in a frequency 10–35 Hz. The IEC 61400-4-15 specifies a flicker meter that can be used to measure flicker directly.

C. Harmonics The harmonic results due to the operation of power electronic converters. The harmonic voltage and current should be limited

to the acceptable level at the point of wind turbine connection to the network. To ensure the harmonic voltage within limit, each source of harmonic current can allow only a limited contribution,as per the IEC-61400-36 guideline. The rapid switching gives a large reduction in lower order harmonic current compared

to the line commutated converter, but the output current will have high frequency current and can be easily filter-out.

D. Wind Turbine Location in Power System

The way of connecting the wind generating system into the power system highly influences the power quality. Thus the operation and its influence on power system depend on the structure of the adjoining power network.

E. Self Excitation of Wind Turbine Generating System

The self excitation of wind turbine generating system (WTGS) with an asynchronous generator takes place after disconnection of wind turbine generating system (WTGS)with local load. The risk of self excitation arises

especially when WTGS is equipped with compensating capacitor. The capacitor connected to induction generator provides reactive power compensation. However the voltage and frequency are determined by the balancing of the system. The disadvantages of self excitation are the safety aspect and balance between real and reactive power [5].

F. Consequences of the Issues

The voltage variation, flicker, harmonics causes the malfunction of equipments namely microprocessor based control system, programmable logic controller; adjustable speed drives, flickering of light and screen. It may leads to tripping of contractors, tripping of protection devices, stoppage of sensitive equipments like personal computer, programmable logic control system and may stop the process and even can damage of sensitive equipments. Thus it degrade the power quality in the grid.

III. GRID COORDINATION RULE

The American Wind Energy Association (AWEA) led the effort in the united state for adoption of the grid code for the interconnection of the wind plants to the utility system. The first grid code was focused on the distribution level, after the blackout in the United State in August 2003. The United State wind energy

industry took a stand in developing its own grid code for contributing to a stable grid operation. The rules for realization of grid operation of wind generating system at the distribution network are defined as-per IEC-61400-21. The grid quality characteristics and limits are given for references that the customer and the utility grid may expect. According to Energy-Economic Law, the operator of transmission grid is responsible for the organization and operation of interconnected system [6].

1) Voltage Rise (u): The voltage rise at the point of common coupling can be approximated as a function of maximum apparent power of the turbine, the grid impedances R and X at the point of common coupling and the phase angle [7], given in (1)

$$\Delta u = S_{max}(R \cos \phi - X \sin \phi) / U^2 \dots\dots\dots(1)$$

where Δu —voltage rise, S_{max} —max. apparent power,—phase difference, U is the nominal voltage of grid.The Limiting voltage rise value is %

2) Voltage Dips (d): The voltage dips is due to start up of wind turbine and it causes a sudden reduction of voltage. It is the relative % voltage change due to switching operation of wind turbine.

$$d = K_u \frac{S_n}{S_K} \dots\dots\dots(2)$$

The decrease of nominal voltage change is given in (2).(2)where is relative voltage change, S_n rated apparent power, short circuit apparent power, and K_u sudden voltage reduction factor. The acceptable voltage dips limiting value is $\leq 3\%$.

3) *Flicker*: The measurements are made for maximum number of specified switching operation of wind turbine with 10-min period and 2-h period are specified, as given in (3)(3)Where —Long term flicker. —Flicker coefficient calculated from Rayleigh distribution of the wind speed.

The Limiting

Value for flicker coefficient is about , for average time of 2 h [8].

$$P_{fl} = C(\Psi_K) \frac{S_n}{S_K} \dots\dots\dots(3)$$

4) *Harmonics*: The harmonic distortion is assessed for variable speed turbine with a electronic power converter at the point of common connection [9]. The total harmonic voltage distortion of voltage is given as in (4):

$$V_{THD} = \sqrt{\sum_{h=2}^{40} \frac{V_n^2}{V_1^2}} \cdot 100 \dots\dots\dots(4)$$

where is the n th harmonic voltage and is the fundamental frequency (50) Hz. The THD limit for 132 KV is % .THD of current is given as in (5)

$$I_{THD} = \sqrt{\sum \frac{I_n}{I_1}} \cdot 100 \dots\dots\dots(5)$$

5) *Grid Frequency*: The grid frequency in India is specified in the range of 47.5–51.5 Hz, for wind farm connection. The wind farm shall able to withstand change in frequency up to 0.5

IV. TOPOLOGY FOR POWER QUALITY IMPROVEMENT

The STATCOM based current control voltage source inverter injects the current into the grid in such a way that the source current are harmonic free and their phase-angle with respect to source voltage has a desired value. The injected current will cancel out the reactive part and harmonic part of the load and

induction generator current, thus it improves the power factor and the power quality. To accomplish these goals, the grid voltages are sensed and are synchronized in generating the current command for the inverter. The proposed grid connected system is implemented for power quality improvement at point of common coupling (PCC), as shown in Fig. 1.The grid connected system in Fig. 1, consists of

wind energy generation system and battery energy storage system with STATCOM.

A. Wind Energy Generating System

In this configuration, wind generations are based on constant speed topologies with pitch control turbine. The induction generators used in the proposed scheme because of its simplicity ,it does not require a separate field circuit, it can accept constant and variable loads, and has natural protection against short circuit.The available power of wind energy system is presented asunder in (6).

$$P_{wind} = \frac{1}{2} \rho A V_{wind}^3 \dots\dots\dots(6)$$

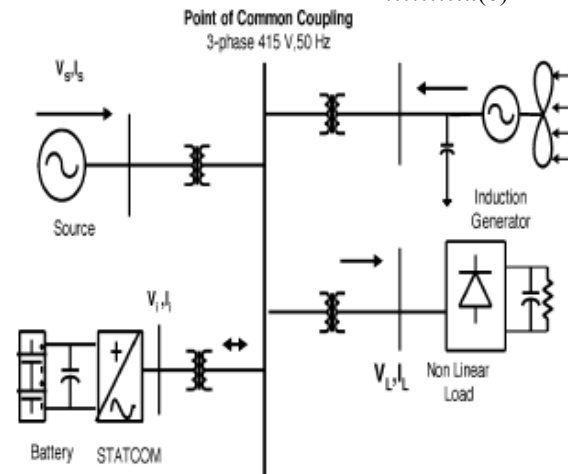

Fig.1 Grid connected system for power quality improvement

where (kg/m) is the air density and A (m) is the area swept out by turbine blade, is the wind speed in mtr/s. It is not possible to extract all kinetic energy of wind, thus it extract a fraction of power in wind, called power coefficient C_p of the wind turbine, and is given in (7).

$$P_{mech} = C_p P_{wind} \dots\dots\dots(7)$$

(7)where C_p is the power coefficient, depends on type and operating condition of wind turbine. This coefficient can be express as a function of tip speed ratio and pitch angle . The mechanical power produce by wind turbine is given in (8)

$$P_{mech} = \frac{1}{2} \rho A R^2 V_{wind}^3 C_p \dots\dots\dots(8)$$

where is the radius of the blade (m).

B. BESS-STATCOM

The battery energy storage system (BESS) is used as an energy storage element for the purpose of voltage regulation. The BESS will naturally maintain dc capacitor voltage constant and is best suited in STATCOM since it rapidly injects or absorbed reactive power to stabilize the grid system. It also control the distribution and transmission

system in a very fast rate. When power fluctuation occurs in the system, the BESS can be used to level the power fluctuation by charging and discharging operation. The battery is connected in parallel to the dc capacitor of STATCOM [10]–[14].

C. System Operation

The shunt connected STATCOM with battery energy storage is connected with the interface of the induction generator and non-linear load at the PCC in the grid system. The STATCOM compensator output is varied according to the controlled MOHOD

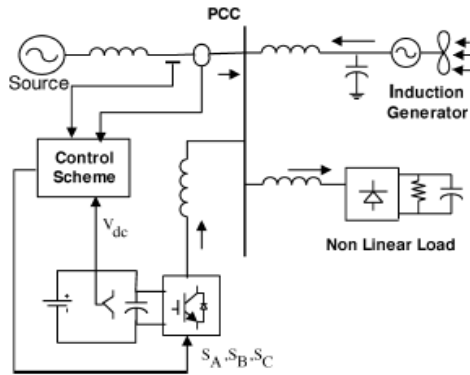

Fig. 2. System operational scheme in grid system.

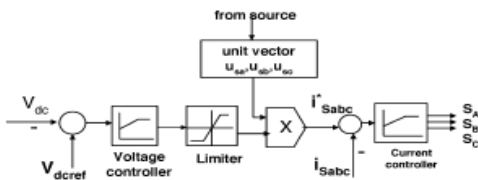

Fig. 3. Control system scheme.

strategy, so as to maintain the power quality norms in the grid system. The current control strategy is included in the control scheme that defines the functional operation of the STATCOM compensator in the power system. A single STATCOM using

insulated gate bipolar transistor is proposed to have a reactive power support, to the induction generator and to the nonlinear he grid system. The main block diagram of the system operational scheme is shown in Fig. 2.

V. CONTROL SCHEME

The control scheme approach is based on injecting the currents into the grid using “bang-bang controller.” The controller uses a hysteresis current controlled technique. Using such technique, the controller keeps the control system variable between boundaries of hysteresis area and gives correct switching signals for STATCOM operation.

The control system scheme for generating the switching signals to the STATCOM is shown in Fig. 3. The control algorithm needs the measurements of several variables such as three-phase source current , DC voltage, inverter current

with the help of sensor. The current control block, receives an input of reference current and actual current are subtracted so as to activate the operation of STATCOM in current control mode [16]–[18].

A. Grid Synchronization

In three-phase balance system, the RMS voltage source amplitude is calculated at the sampling frequency from the source phase voltage and is expressed, as sample template V_{sm} , sampled peak voltage, as in (9).

$$V_{sm} = \left\{ \frac{2}{3} (V_{sa}^2 + V_{sb}^2 + V_{sc}^2) \right\}^{1/2} \dots (9)$$

The in-phase unit vectors are obtained from AC source—phase voltage and the RMS value of unit vector as shown in (10).

$$u_{sa} = \frac{V_{sa}}{V_{sm}}, \quad u_{sb} = \frac{V_{sb}}{V_{sm}}, \quad u_{sc} = \frac{V_{sc}}{V_{sm}}, \dots (10)$$

The in-phase generated reference currents are derived using in-phase unit voltage template as, in (11)

$$i_{sa}^* = I \cdot u_{sa}, \quad i_{sb}^* = I \cdot u_{sb}, \quad i_{sc}^* = I \cdot u_{sc} \dots (11)$$

where is proportional to magnitude of filtered source voltage for respective phases. This ensures that the source current is controlled to be sinusoidal. The unit vectors implement the important function in the grid connection for the synchronization for STATCOM. This method is simple, robust and favorable as compared with other methods [18].

B. Bang-Bang Current Controller

Bang-Bang current controller is implemented in the current control scheme. The reference current is generated as in (10) and actual current are detected by current sensors and are subtracted for obtaining a current error for a hysteresis based bang-bang controller. Thus the ON/OFF switching signals for IGBT of STATCOM are derived from hysteresis controller [19]. The switching function for phase ‘a’ is expressed as (12).

$$\begin{aligned} i_{sa} < (i_{sa}^* - HB) &\rightarrow S_A = 0 \\ i_{sa} > (i_{sa}^* + HB) &\rightarrow S_A = 1 \end{aligned} \dots (12)$$

where HB is a hysteresis current-band, similarly the switching function can be derived for phases “b” and “c”.

VI. SYSTEM PERFORMANCE

The proposed control scheme is simulated using SIMULINK in power system block set. The system parameter for given system is given Table I.

The system performance of proposed system under dynamic condition is also presented.

A. Voltage Source Current Control—Inverter Operation

The three phase injected current into the grid from

STATCOM will cancel out the distortion caused by the nonlinear load and wind generator. The IGBT based three-phase inverter is connected to grid through the transformer.

Table 1
System parameters

S.N.	Parameters	Ratings
1	Grid Voltage	3-phase ,415V,50 Hz
2	Induction Motor/Generator	3.35 kVA,415V, 50 Hz, P = 4, Speed = 1440 rpm, $R_s = 0.01\Omega$, $R_r = 0.015\Omega$, $L_s = 0.06H$, $L_r = 0.06H$
3	Line Series Inductance	0.05mH
4	Inverter Parameters	DC Link Voltage = 800V, DC link Capacitance = 100 μ F. Switching frequency = 2 kHz.
5	IGBT Rating	Collector Voltage =1200V, Forward Current =50A, Gate voltage =20V, Power dissipation = 310W
6	Load Parameter	Non-linear Load 25kW.

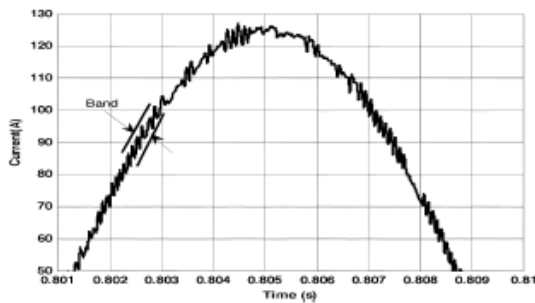

Fig. 4. Switching signal within a control hysteresis band.

B. STATCOM—Performance Under Load Variations

The wind energy generating system is connected with grid having the nonlinear load. The performance of the system is measured by switching the STATCOM at time s in the system and how the STATCOM responds to the step change command for increase in additional load at 1.0 s is shown in the simulation. When STATCOM controller is made ON, without change in any other load condition parameters, it starts to mitigate for reactive demand as well as harmonic current. This additional demand is fulfilled by STATCOM compensator. Thus, STATCOM can regulate the available real power from source. The result of source current, load current are shown in Fig. 6(a) and (b) respectively. While the result of injected current from STATCOM are shown in Fig. 6(c) and the generated current from wind generator at PCC are depicted in Fig. 6(d).

The DC link voltage regulates the source current in the grid system, so the DC link voltage is maintained constant across the capacitor as shown in Fig. 7(a). The current

through the dc link capacitor indicating the charging and discharging operation as shown in Fig. 7(b)

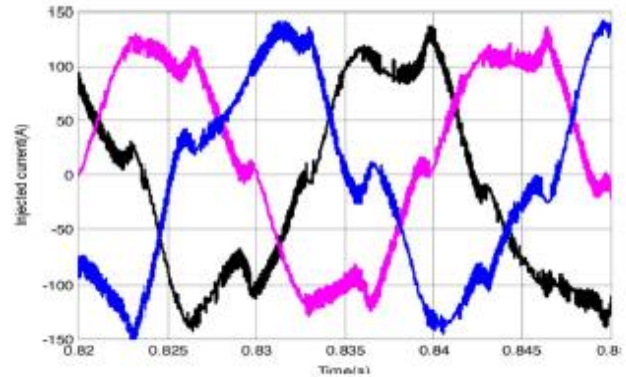

Fig. 5. Three phase injected inverter Current.

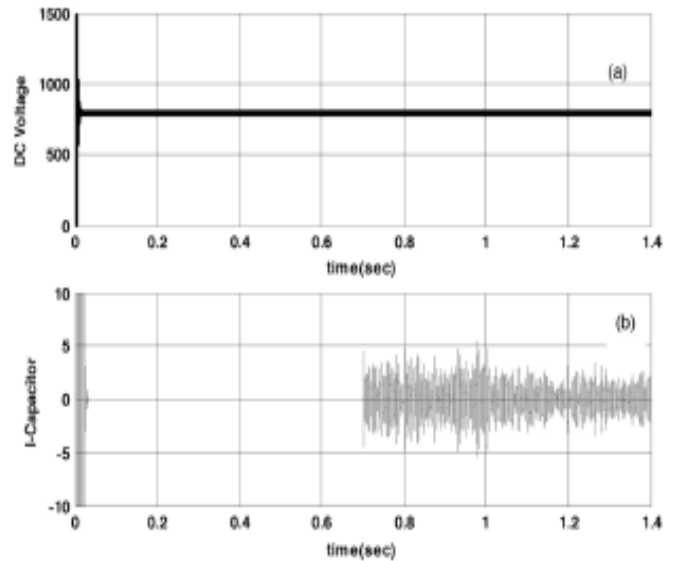
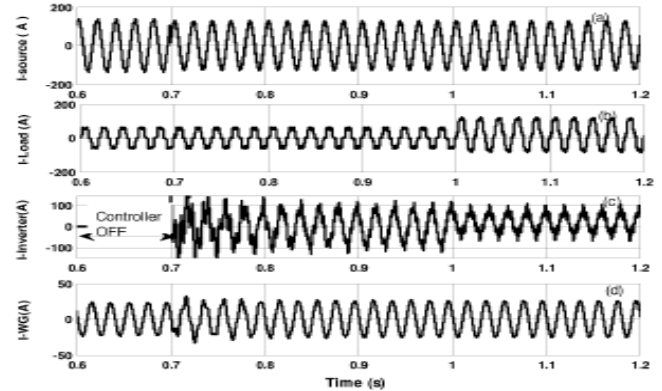

Fig. 7. (a) DC link voltage. (b) Current through Capacitor.

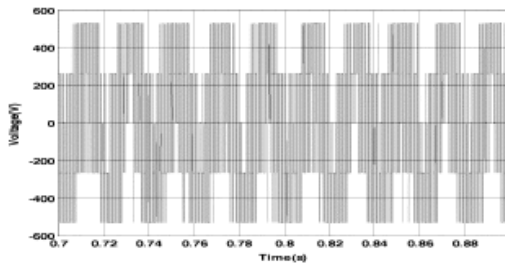

Fig. 8. STATCOM output voltage.

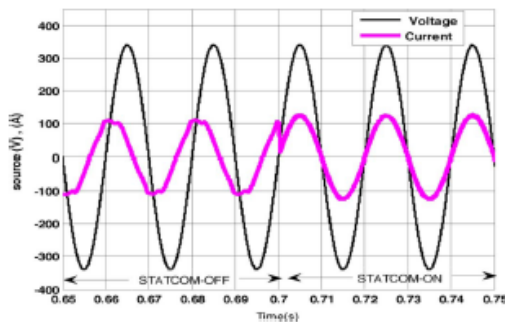

Fig. 9. Supply Voltage and Current at PCC.

C. Power Quality Improvement

It is observed that the source current on the grid is affected due to the effects of nonlinear load and wind generator, thus purity of waveform may be lost on both sides in the system. The inverter output voltage under STATCOM operation with load variation is shown in Fig. 8. The dynamic load does affect the inverter output voltage. The source current with and without STATCOM operation is shown in Fig. 9. This shows that the unity power factor is maintained for the source power when the STATCOM is in operation. The current waveform before and after the STATCOM operation is analyzed. The Fourier analysis of this waveform is expressed and the THD of this source current at PCC without STATCOM is 4.71%, as shown in Fig. 10. The power quality improvement is observed at point of common coupling, when the controller is in ON condition. The STATCOM is placed in the operation at 0.7 s and source current waveform is shown in Fig. 11 with its FFT. It is shown that the THD has been improved considerably and within the norms of the standard. The above tests with proposed scheme has not only power quality improvement feature but it also has sustain capability to support the load with the energy storage through the batteries.

VII. CONCLUSION

This paper presents the STATCOM-based control scheme for power quality improvement in grid connected wind generating system and with non linear load. The power quality issues and its consequences on the consumer and electric utility are presented. The operation of the control

system developed for the STATCOM-BESS in MATLAB/SIMULINK for maintaining the power quality is simulated. It has a capability to cancel out the harmonic parts of the load current. It maintains the source voltage and current in-phase and support the reactive power demand for the wind generator and load at PCC in the grid system, thus it gives an opportunity to enhance the utilization factor of transmission line. The integrated wind generation and STATCOM with BESS have shown the outstanding performance. Thus the proposed scheme in the grid connected system fulfills the power quality norms as per the IEC standard 61400-21.

REFERENCES

- [1] A. Sannino, "Global power systems for sustainable development," in *IEEE General Meeting*, Denver, CO, Jun. 2004.
- [2] K. S. Hook, Y. Liu, and S. Atcity, "Mitigation of the wind generation integration related power quality issues by energy storage," *EPQU J.*, vol. XII, no. 2, 2006.
- [3] R. Billinton and Y. Gao, "Energy conversion system models for adequacy assessment of generating systems incorporating wind energy," *IEEE Trans. on E. Conv.*, vol. 23, no. 1, pp. 163–169, 2008, Multistate.
- [4] *Wind Turbine Generating System—Part 21*, International standard-IEC61400-21, 2001.
- [5] J. Manel, "Power electronic system for grid integration of renewable energy source: A survey," *IEEE Trans. Ind. Electron.*, vol. 53, no. 4, pp. 1002–1014, 2006, arrasco.
- [6] M. Tsili and S. Papathanassiou, "A review of grid code technology requirements for wind turbine," *Proc. IET Renew. power gen.*, vol. 3, pp. 308–332, 2009.
- [7] S. Heier, *Grid Integration of Wind Energy Conversions*. Hoboken, NJ: Wiley, 2007, pp. 256–259.
- [8] J. J. Gutierrez, J. Ruiz, L. Leturiondo, and A. Lazkano, "Flicker measurement system for wind turbine certification," *IEEE Trans. Instrum. Meas.*, vol. 58, no. 2, pp. 375–382, Feb. 2009.
- [9] Indian Wind Grid Code Draft report on, Jul. 2009, pp. 15–18, C-NET.
- [10] C. Han, A. Q. Huang, M. Baran, S. Bhattacharya, and W. Litzemberger, "STATCOM impact study on the integration of a large wind farm into a weak loop power system," *IEEE Trans. Energy Conv.*, vol. 23, no. 1, pp. 226–232, Mar. 2008.
- [11] D. L. Yao, S. S. Choi, K. J. Tseng, and T. T. Lie, "A statistical approach to the design of a dispatchable wind power—Battery energy storage system," *IEEE Trans. Energy Conv.*, vol. 24, no. 4, Dec. 2009.