

Modeling and Analyses of Cascaded H-Bridge Five Level Multilevel Converter for Micro Grid Application

1 SHAIK NAGOOR VALI 2 KALLURI VENKATESWARLU

1PG Scholar , Department of Electrical & Electronics Engineering, PACE Institute of Technology & Sciences, Ongole , AP, India. e-mail: sknagoorvali45@gmail.com

2Assistant Professor in Electrical & Electronics Engineering Department, PACE Institute of Technology & Sciences, Ongole , AP, India. e-mail: kalluri.venkateswarlu@gmail.com

Abstract- The concept of multilevel inverters introduced about 20 years ago entails performing power conversion in multiple voltage steps to obtain improved power quality, lower switching losses, better electromagnetic compatibility, and higher voltage capability. The benefits are especially clear for medium-voltage drives in industrial applications and are being considered for future naval ship propulsion systems. Several topologies for multilevel inverters have been proposed over the years; the most popular cascaded H-bridge apart from other multilevel inverters is the capability of utilizing different dc voltages on the individual H-bridge cells which results in splitting the power conversion amongst higher-voltage lower-frequency and lower-voltage higher-frequency inverters. Considering the cascaded inverter to be one unit, it can be seen that a higher number of voltage levels are available for a given number of semiconductor devices. In this paper a 5 level Cascaded H-Bridge for micro grid application is proposed. Considering the system as separate inverters, the cascaded design can be regarded as a combination of a bulk power (higher-voltage) inverter and a conditioning (lower-power) inverter. A SIMULINK based model is developed and Simulation results are presented

Keywords- Cascaded H-Bridge, Five level Multilevel Converter, PWM, Micro Grid

I. INTRODUCTION

Fossil fuels are running out and current centralized power generation plants are inefficient with a significant amount of energy lost as heat to the environment, in addition to producing harmful emissions and greenhouse gases. Furthermore, current power systems, especially in developing countries, suffer from several limitations such as high cost of expansion and efficiency improvement limits within existing grid infrastructure. Renewable energy sources can help address these issues, but it can be a challenge to get stable power from these sources as they are variable in nature. Distributed generators (DG), including renewable sources, within micro grids can help overcome power system limitations, improve efficiency, reduce emissions and manage the variability of renewable sources. A micro grid, a relatively new concept, is a zone within the main grid where a cluster of electrical loads and small micro generation systems such as solar cell, fuel cell, wind turbine and small combined heat and power (CHP) systems exist together under an embedded management and control system with the option of storage devices. Other benefits of generating power close to electrical loads include the use of waste heat locally, saving the cost of upgrading the grid to supply more power from central plants, reducing transmission losses and creating opportunities for increasing competition in the sector which can stimulate innovation and reduce consumer prices [1, 2].

Power electronic converters are used in micro grids to control the flow of power and convert it into suitable DC or AC form as required. With the advancement of power electronics and emergence of new multilevel converter topologies, it is possible to work at voltage levels beyond the classic semiconductor limits. The multilevel converters achieve high-voltage switching by means of a series of voltage steps, each of which lies within the ratings of the individual power devices. Among the multilevel Converters [1-4], the cascaded H-bridge topology (CHB) is particularly attractive in high-voltage applications, because it requires the least number of components to synthesize the same number of voltage levels.

Additionally, due to its modular structure, the hardware implementation is rather simple and the maintenance operation is easier than alternative multilevel converters. The multilevel voltage source inverter is recently applied in many industrial applications such as ac power supplies, static VAR compensators, drive systems, etc. One of the significant advantages of multilevel configuration is the harmonic reduction in the output waveform without increasing switching frequency or decreasing the inverter power output [5-10]. The output voltage waveform of a multilevel inverter is composed of the number of levels of voltages, typically obtained from capacitor voltage sources. The so-called multilevel starts from

three levels. As the number of levels reach infinity, the output THD approaches zero. The number of the achievable voltage levels, however, is limited by voltage unbalance problems voltage clamping requirement, circuit layout, and packaging constraints.

II. MODES OF OPERATION OF MICROGRID CONVERTERS

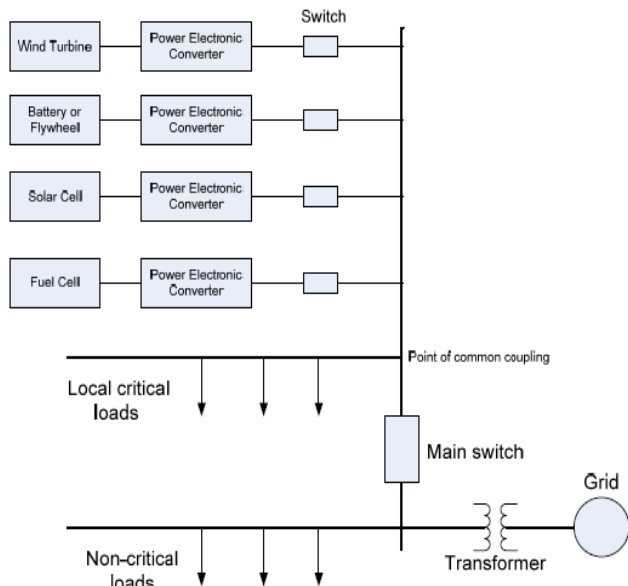

Fig. 1. A Schematic Diagram of a Micro grid

Normally, converters are used to connect DG systems in parallel with the grid or other sources, but it may be useful for the converters to continue functioning in stand-alone mode, when the other sources become unavailable to supply critical loads. Converters connected to batteries or other storage devices will also need to be bidirectional to charge and discharge these devices.

A. Grid Connection Mode:

In this mode of operation, the converter connects the power source in parallel with other sources to supply local loads and possibly feed power into the main grid. Parallel connection of embedded generators is governed by national standards [7-9]. The standards require that the embedded generator should not regulate or oppose the voltage at the common point of coupling, and that the current fed into the grid should be of high quality with upper limits on current total harmonic distortion THD levels. There is also a limit on the maximum DC component of the current injected into the grid. The power injected into the grid can be controlled by either direct control of the current fed into the grid [10], or by controlling the power angle. In the latter case, the voltage is controlled to be sinusoidal. Using power angle control however, without directly controlling the output current, may not be effective at reducing the output current THD when the grid voltage is highly distorted, but this will be an issue in the case of electric machine generators, which effectively use

power angle control. This raises the question of whether it is reasonable to specify current THD limits, regardless of the quality of the utility voltage. In practice, the converter output current or voltage needs to be synchronized with the grid, which is achieved by using a phase locked loop or grid voltage zero crossing detection. The standards also require that embedded generators, including power electronic converters, should incorporate an anti-islanding feature, so that they are disconnected from the point of common coupling when the grid power is lost. There are many anti-islanding techniques; the most common of these is the rate of change of frequency (RoCoF) technique.

B. Stand-Alone Mode

It may be desirable for the converter to continue to supply a critical local load when the main grid is disconnected, e.g. by the anti-islanding protection system. In this stand-alone mode the converter needs to maintain constant voltage and frequency regardless of load imbalance or the quality of the current, which can be highly distorted if the load is nonlinear. A situation may arise in a microgrid, disconnected from the main grid, where two or more power electronic converters switch to stand-alone mode to supply a critical load. In this case, these converters need to share the load equally. The equal sharing of load by parallel connected converter operating in stand-alone mode requires additional control. There are several methods for parallel connection, which can be broadly classified into two categories: 1) Frequency and voltage droop method, 2) Master-slave method, whereby one of the converters acts as a master setting the frequency and voltage, and communicating to the other converters their share of the power.

C. Battery Charging Mode

In a micro grid, due to the large time constants of some micro sources, storage batteries should be present to handle disturbances and fast load changes . In other words, energy storage is needed to accommodate the variations of available power generation and demand. The power electronic converter could be used as a battery charger thus improving the reliability of the micro grid.

III. MODELING OF VARIOUS RENEWABLE ENERGY SOURCES

A Modeling of PV system

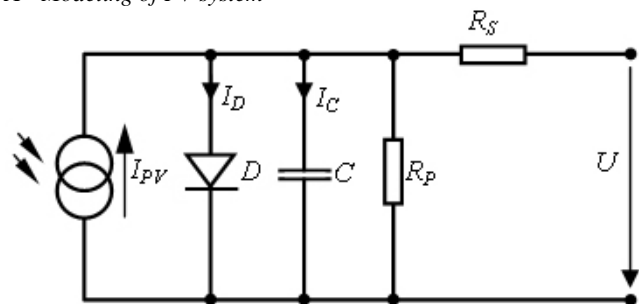

The use of equivalent electric circuits makes it possible to model characteristics of a PV cell. The method used here is

implemented in MATLAB programs for simulations. The same modeling technique is also applicable for modeling a PV module. There are two key parameters frequently used to characterize a PV cell. Shorting together the terminals of the cell, the photon generated current will follow out of the cell as a short-circuit current (I_{sc}). Thus, $I_{ph} = I_{sc}$, when there is no connection to the PV cell (open-circuit), the photon generated current is shunted internally by the intrinsic p-n junction diode. This gives the open circuit voltage (V_{oc}). The PV module or cell manufacturers usually provide the values of these parameters in their datasheets [14].

B Modeling of Wind system

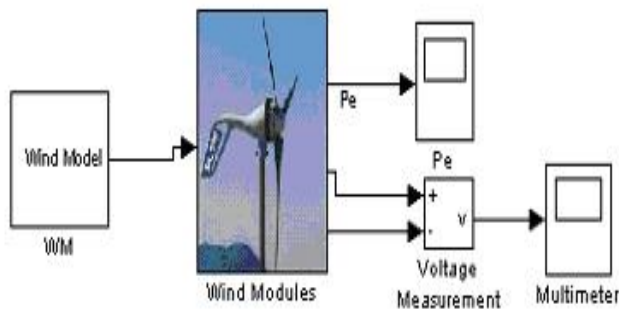

The wind turbine depends on the flow of air in a rotor consisting of two or three blades mechanically coupled to an electrical generator. It is a process of power translation from wind energy to electricity. The difference between the upstream and downstream wind powers is actual power extracted by the rotor blades,. It is given by the following equation in units of watts.

$$P_M = \frac{1}{2} \rho A \{V^2 - V_0^2\}$$

C Modeling of Hydro system

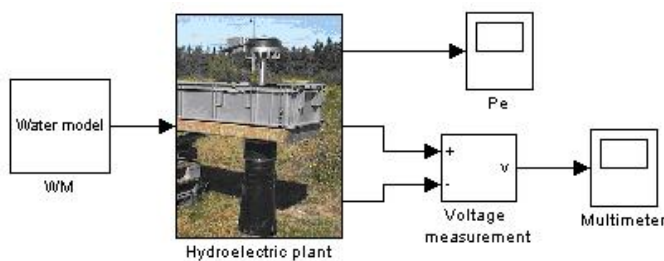

Small hydroelectric power plants harness the falling water kinetic energy to generate electricity. Turbines transform falling water kinetic energy into mechanical rotation energy and then, the alternator transforms the mechanical energy into electricity. Water flows within a river from a higher geodesic site to a lower geodesic site due to gravitation. This is characterized by different particular kinetic and potential energy at both sites. The correct

identification of the resulting energy differences of the out-flowing water can be assumed by considering a stationary and friction-free flow with incompressibility.

$$p + \rho_{water}gh + \frac{1}{2} \rho_{water}v_{water}^2 = const$$

D Modeling of Battery

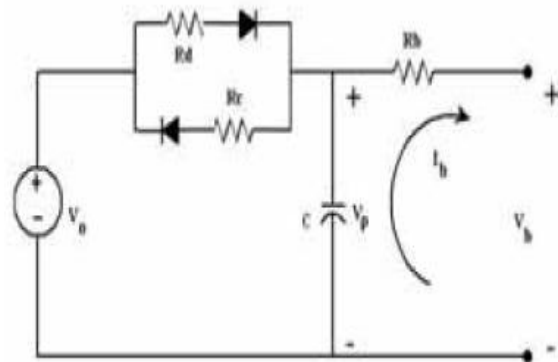

The open circuit voltage, internal capacitor voltage and the terminal voltage are represented by V_0 , V_p and V_b . The charging, discharging and the internal resistance of the battery are represented by R_e , R_d and R_b and the polarization capacitance of the battery is represented by C . The current I_b is taken as positive if discharging and negative otherwise (Vairamohan, 2002).

$$\dot{V}_p = \frac{1}{C} \left(\left(\frac{V_0 - V_p}{R_d} \right) - I_b \right)$$

IV. HIGH POWER CONVERTERS CLASSIFICATIONS

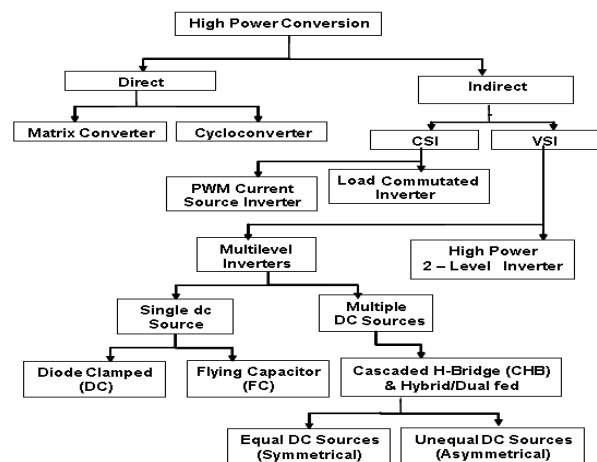

Figure 2 Classification of High power Converters

Fig.2 shows the classification of high power converters. Out of all converters Cascaded bridge configuration is more popular.

Cascaded bridge configuration is again classified into 2 types
 1) Cascaded Half Bridge 2) Cascaded Full Bridge or Cascaded H-Bridge. In this paper a novel cascaded hybrid H- Bridge topology is proposed for PV application.

number output voltage levels of cascaded Full H-Bridge are given by $2n+1$ and voltage step of each level is given by V_{dc}/n . Where n is number of H-bridges connected in cascaded. The switching table is given in Table2.

Table 1. Switching table for Full H-Bridge

Switches Turn ON	Voltage Level
S1,S2	V_{dc}
S3,S4	$-V_{dc}$
S4,D2	0

A Half H-Bridge

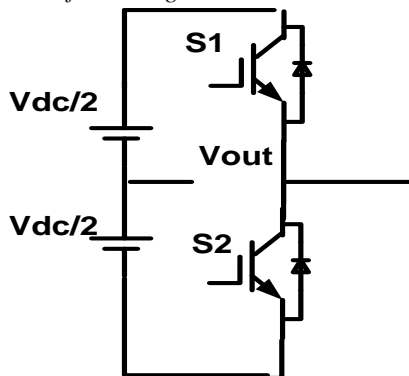

Figure 3 Half Bridge

Fig.3 shows the Half H-Bridge Configuration. By using single Half H-Bridge we can get 2 voltage levels. The switching table is given in Table 1.

Table 1. Switching table for Half Bridge

Switches Turn ON	Voltage Level
S2	$V_{dc}/2$
S1	$-V_{dc}/2$

B Full H-Bridge

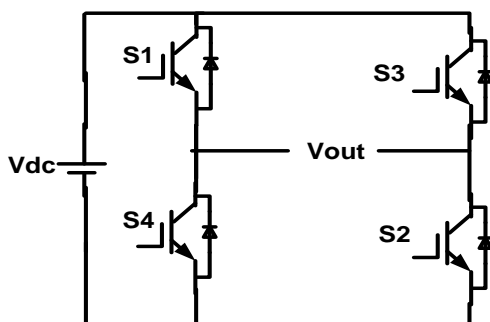

Figure 4 Full H-Bridge

Fig.3 shows the Full H-Bridge Configuration. By using single H-Bridge we can get 3 voltage levels. The

V.MATLAB/SIMULINK MODELING AND SIMULATION RESULTS

Fig. 7 and 9 shows the Matlab/Simulink model of Hybrid H-bridge and cascaded Hybrid H-bridge converters respectively.

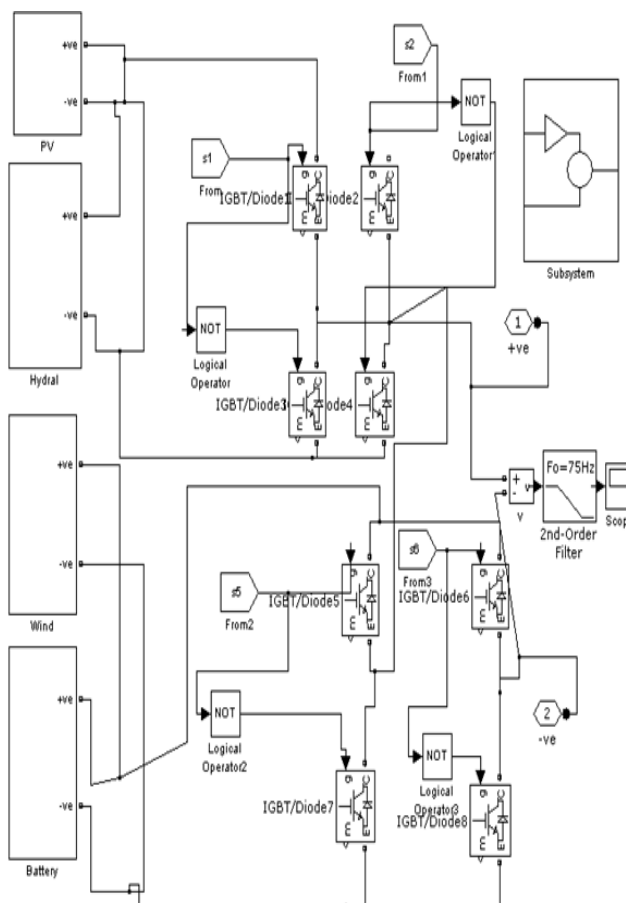

Figure 5 Matlab/Simulink model of Micro grid

Fig. 5 shows the Matlab/Simulink model of Micro grid system. It consists of two cascaded H-Bridges. One H-bridg is supplied with PV and Hydral system and second H-bridge is supplied with Wind and Battery sytem.

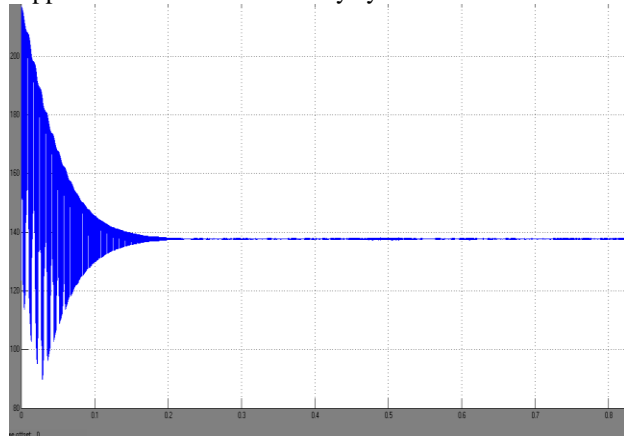

Figure. 6 Output PV and Hydral system

Fig.6 shows the combined output of PV and Hydral system. The output voltage is 130 v DC.

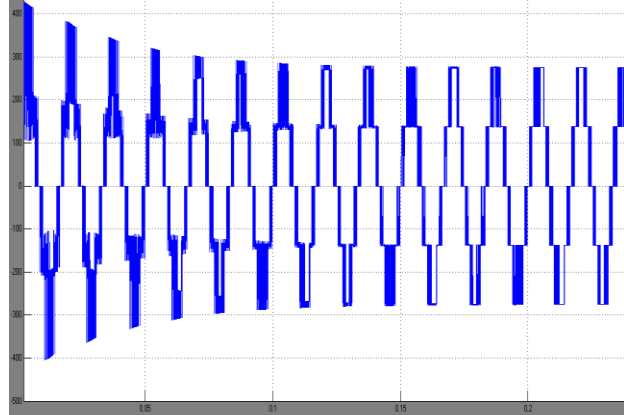

Figure. 7 Five level output Multilevel Inverter without filter

Fig. 7 shows the five level output of multilevel inverter with out filter and Fig.8 shows output voltage with filter. Peak voltage here is 280 v.

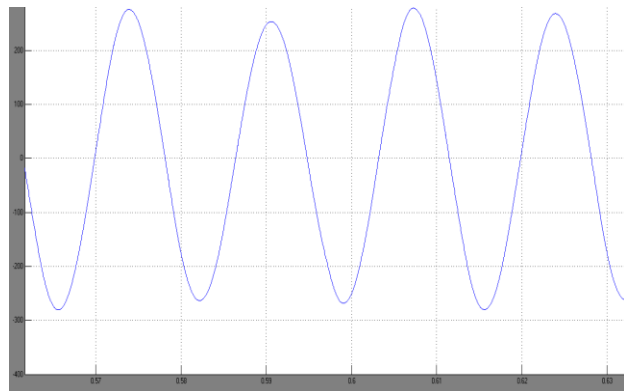

Figure. 8Sine wave output of Multilevel Inverter with filter

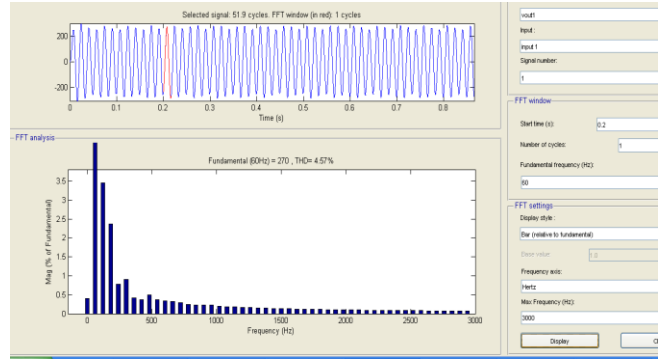

Figure. 9 THD

Fig. 9 shows output voltage THD. Form the figure it is clear that THD of output voltage is 4.1 %.

VI. CONCLUSION

A particular MG architecture has been modeled in order to analyse its behaviour during grid connected and islanding operation. The model is based on a wind turbine, a PV panels array, a backup DG and a VSI used for the interconnection with the main grid.. A SIMULINK based model is developed and Simulation results are presented. Finally PWM based output is shown.

VII. REFERENCES

- [1] J. S. Lai and F. Z. Peng, “Multilevel converters – A new breed of power converters”, IEEE Trans. Ind. Appl., V32, No. 3, pp. 509-517, May/June, 1996.
- [2] José Rodríguez, Jih-Sheng Lai, FangZhengPeng “Multilevel Inverters: A Survey of Topologies, Controls, and Applications” IEEE Trans. Ind. App, VOL. 49, NO. 4, August 2002.
- [3] K.A Corzine, and Y.L Familant, “A New Cascaded Multi-level H-Bridge Drive,” IEEE Trans. Power.Electron., vol.17, no.1, pp.125-131. Jan 2002.
- [4]T.A.Maynard, M.Fadel and N.Aouda, “Modelling of multilevel converter,” IEEE Trans. Ind.Electron., vol.44, pp.356-364. Jun.1997.
- [5] Manjrekar, M. D., Lipo, T. A. “A hybrid multilevel inverter topology for drive applications”. in Proc. of APEC, 1998, p. 523–529.
- [6] R. Schnell, U. Schlapbach, “Realistic benchmarking of IGBT – modules with the help of a fast and easy to use simulation tool”.
- [7] Jean-Philippe Hasler, “DC Capacitor Sizing for SVC Light Industrial Application”.
- [8]G.Carrara, S.Gardella, M.Marchesoni, R.salutari,and G.sciutto, “A New Multilevel PWM Method; A theoretical analysis,” IEEE Trans. Power.Electron., vol.7, no.3, pp.497-505. Jul.1992.
- [9]L.M.Tolber, T.G.Habetler, “Novel Multilevel inverter Carrier based PWM Method,” IEEE Ind.Appli., vol.35. pp.1098-1107. Sep/Oct 1999.
- [10]Holmes, D. G. and Lipo, T. A., Pulse width modulation for power converters: principles and practice, IEEE.