

Reactive Power Compensation And Harmonics Mitigation Using Multi Level Inverter Based D-Statcom With Flc Controller

M.Malleswararao¹, M.Balasubba reddy², SK.Meera shareef³

1 PG Scholar, Dept of EEE Prakasam Engineering College, Kandukur.

2 Professor, Head of the Department, Dept of EEE Prakasam Engineering College, Kandukur.

3 Associate Professor, Dept of EEE Prakasam Engineering College, Kandukur.

Abstract

An investigation of multilevel inverter based Distribution static compensator (D-STATCOM) with FLC in Power distribution System (PDS) for compensation of reactive power and harmonics mitigation. Cascaded H-bridge inverters having several advantages over conventional swathing devices are low harmonic distortion, reduced number of switches there by suppression of switching losses.

The Distribution static compensator D-STATCOM is a shunt connected fast acting reliable FACTS device. Which can able to generate and absorb the reactive power based on load requirement in distribution system. It can also helps for power factor improvement, voltage stability enhancement, stability profile improvement and also eliminate the Total Harmonics Distortion (THD) drawn from a Non-Liner Diode Rectifier Load (NLDRL). Here D-Q reference frame theory is used to generate them reference compensating currents for D-STATCOM while Fuzzy controller (FC) is used for capacitor dc voltage regulation. A CHB Inverter is considered for shunt compensation of a 11 kV secondary distribution system.

Finally a level shifted PWM (LSPWM) & Phase shifted PWM (PSPWM) technique adopted to analyze the performance of CHB Inverter for the proposed scheme. The results are obtained through Mat lab/ Simulink software tool box.

Keywords: D-STATCOM, Level shifted Pulse width modulation (LSPWM), Phase shifted Pulse width modulation (PSPWM), Proportional-Integral (PI) control, CHB multilevel inverter, D-Q reference frame theory.

1. INTRODUCTION

Modern power system is a complex dynamic networks, where large number of generating stations and loads are interconnected through long power transmission and distribution networks. Even though the power Generation is fairly reliable; the quality of power is not always so reliable the base reason for this is contingencies which are undesirable. Power distribution system should provide with an reliable flow of energy at smooth sinusoidal voltage at the contracted magnitude level and Frequency to have reliable power to all customers. In whole of PS network especially distribution system has large number of non linear loads, which significantly affect the quality of power. Apart from nonlinear loads, events like capacitor switching, motor starting and unusual faults could also inflict power quality (P-Q) problems. P-Q problem is defined as any manifested problem in voltage current or leading to frequency deviations that result in failure or maloperation of customer equipments. Voltage sags and swells are among the many P-Q problems the industrial processes have to face. Voltage sags are more severe. During the past few decades, power industries have proved that the adverse impacts on the P-Q can be mitigated or avoided by conventional means, and that techniques using fast controlled force commutated power electronics (PE) are even more effective. P-Q compensators can be categorized into two main types. One is shunt connected compensation device that effectively eliminates harmonics. The other is the series connected device, which has an edge over the shunt type for correcting the distorted system side voltages

and voltage sags caused by power transmission System contingencies. The STATCOM which used in distribution systems is called D-STATCOM (Distribution-STATCOM) and its configuration is the same, but with small modifications. It can exchange both active and reactive power with the distribution system by varying the amplitude and phase angle of the converter voltage with respect to the line terminal voltage. A multilevel inverter is an efficient advanced power electronic device which reduce the device Harmonics present in output voltage by increasing the number of output voltage levels with small number steps such that high quality output can be possible. There are several types of multilevel inverters: cascaded H-bridge (CHB), neutral point diode-clamped, flying capacitor types. In particular, among these topologies, CHB inverters are being widely used because of their Modularity and simplicity. Various modulation methods can be applied to CHB inverters. CHB inverters can also increase the number of output voltage levels easily by increasing the number of H-bridges. This paper presents a D-STATCOM with a proportional integral controller based CHB multilevel inverter for the harmonics mitigation and reactive power compensation of the nonlinear loads. This type of arrangements have been widely used for P-Q applications due to increase in the number of voltage levels, low switching losses, low electromagnetic compatibility for hybrid filters and higher order harmonic elimination.

2. DESIGN OF MULTILEVEL BASED DSTATCOM

A. Basic Principle of D-STATCOM

A D-STATCOM (Distribution Static Compensator), which is schematically depicted in consists of a two-level Voltage Source Converter (VSC), a dc energy storage device, a coupling transformer connected in shunt to the distribution network through a coupling transformer. The VSC converts the dc voltage across the storage device into a set of three-phase ac output voltages. These voltages are in phase and coupled with the ac system through the reactance of the coupling transformer. Suitable adjustment of the phase and magnitude of the D-STATCOM output voltages allows effective control of active and reactive power exchanges between the DSTATCOM and the ac system. Such configuration allows the device to absorb or generate controllable active and reactive power.

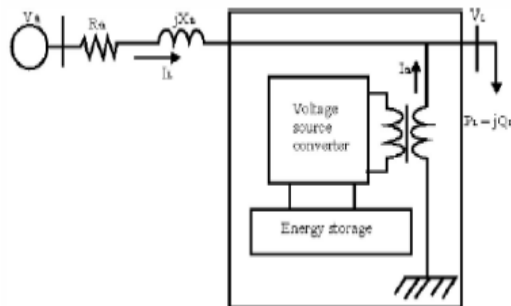

Fig 2.1: Schematic Diagram of a D-STATCOM

The VSC connected in shunt with the ac system provides a multifunctional topology which can be used for up to three quite distinct purposes:

1. Voltage regulation and compensation of reactive power;
2. Correction of power factor
3. Elimination of current harmonics.

Here, such device is employed to provide continuous voltage regulation using an indirectly controlled converter. As shown in Figure-1 the shunt injected current I_{sh} corrects the voltage sag by adjusting the voltage drop across the system impedance Z_{th} . The value of I_{sh} can be controlled by adjusting the output voltage of the converter. The shunt injected current I_{sh} can be written as,

$$I_{sh} = I_L - I_S = I_L - (V_{th} - V_L) / Z_{th}$$

$$I_{sh} / _ \eta = I_L / _ - \theta$$

The complex power injection of the D-STATCOM can be expressed as,

$$S_{sh} = V_L I_{sh}^*$$

It may be mentioned that the effectiveness of the DSTATCOM in correcting voltage sag depends on the value

of Z_{th} or fault level of the load bus. When the shunt injected current I_{sh} is kept in quadrature with V_L , the desired voltage correction can be achieved without injecting any active power into the system. On the other hand, when the value of I_{sh} is minimized, the same voltage correction can be achieved with minimum apparent power injection into the system.

B. Control Reactive Power for Compensation

The aim of the control scheme is to maintain constant voltage magnitude at the point where a sensitive load under system disturbances is connected. The control system only measures the rms voltage at the load point, i.e., no reactive power measurements are required. The VSC switching strategy is based on a sinusoidal PWM technique which offers simplicity and good response. Since custom power is a relatively low-power application, PWM methods offer a more flexible option than the fundamental frequency switching methods favored in FACTS applications. Apart from this, high switching frequencies can be used to improve on the efficiency of the converter, without incurring significant switching losses.

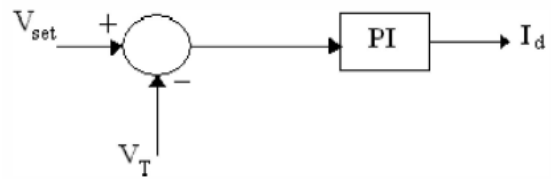

Fig2.2: PI control for reactive power compensation

The controller input is an error signal obtained from the reference voltage and the rms terminal voltage measured. Such error is processed by a PI controller; the output is the angle θ , which is provided to the PWM signal generator. It is important to note that in this case, of indirectly controlled converter, there is active and reactive power exchange with the network simultaneously. The PI controller processes the error signal and generates the required angle to drive the error to zero, i.e. the load rms voltage is brought back to the reference voltage.

C. Control for Harmonics Compensation

The Modified Synchronous Frame method is presented. It is called the instantaneous current component (id-iq) method. This is similar to the Synchronous Reference Frame theory (SRF) method. The transformation angle is now obtained with the voltages of the ac network.

The major difference is that, due to voltage harmonics and imbalance, the speed of the reference frame is no longer constant. It varies instantaneously depending of the waveform of the 3-phase voltage system. In this method the compensating currents are obtained from the

instantaneous active and reactive current components of the nonlinear load. In the same way, the mains voltages V (a, b, c) and the available currents ij (a, b, c) in a-b-c components must be calculated as given by formula, where C is Clarke Transformation Matrix.

However, the load current components are derived from a SRF based on the Park transformation, where θ represents the instantaneous voltage vector angle.

$$\begin{bmatrix} I_{i\alpha} \\ I_{i\beta} \end{bmatrix} = [C] \begin{bmatrix} I_{ia} \\ I_{ib} \\ I_{ic} \end{bmatrix}$$

$$\begin{bmatrix} I_{id} \\ I_{iq} \end{bmatrix} = \begin{bmatrix} \cos\theta & \sin\theta \\ -\sin\theta & \cos\theta \end{bmatrix} \begin{bmatrix} I_{i\alpha} \\ I_{i\beta} \end{bmatrix}, \theta = \tan^{-1} \frac{V_{\beta}}{V_{\alpha}}$$

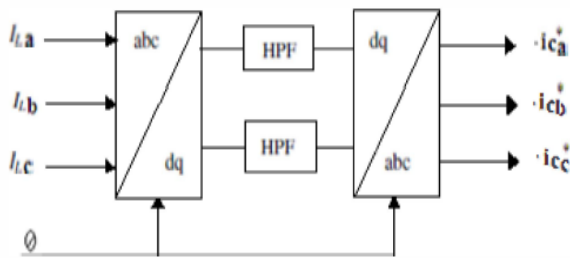

Fig2.3: Block diagram of SRF method

Shows the block diagram SRF method. Under balanced and sinusoidal voltage conditions angle θ is a uniformly increasing function of time. This transformation angle is sensitive to voltage harmonics and unbalance; therefore $d\theta/dt$ may not be constant over a mains period. With transformation given below the direct voltage component is

$$\begin{bmatrix} i_{id} \\ i_{iq} \end{bmatrix} = \frac{1}{\sqrt{V_{\alpha}^2 + V_{\beta}^2}} \begin{bmatrix} V_{\alpha} & V_{\beta} \\ -V_{\beta} & V_{\alpha} \end{bmatrix} \begin{bmatrix} i_{ca} \\ i_{cb} \end{bmatrix}$$

$$\begin{bmatrix} i_{ca} \\ i_{cb} \end{bmatrix} = \frac{1}{\sqrt{V_{\alpha}^2 + V_{\beta}^2}} \begin{bmatrix} V_{\alpha} & -V_{\beta} \\ V_{\beta} & V_{\alpha} \end{bmatrix} \begin{bmatrix} i_{cd} \\ i_{cq} \end{bmatrix}$$

$$\begin{bmatrix} I_{Comp,a} \\ I_{Comp,b} \\ I_{Comp,c} \end{bmatrix} = [C]^T \begin{bmatrix} i_{c\alpha} \\ i_{c\beta} \end{bmatrix}$$

D. Cascaded H-Bridge Multilevel Inverter

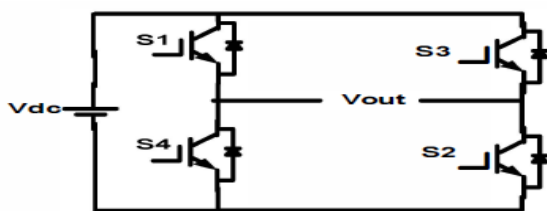

Fig2.4: Circuit of the single cascaded H-Bridge Inverter

The circuit model of a single CHB inverter configuration. By using single H-Bridge we can get 3 voltage levels. The number of output voltage levels of CHB is given by $2n+1$ and voltage step of each level is given by $V_{dc}/2n$, where n is number of H-Bridges connected in cascaded. The switching table is given in Table 9.

Table2.1 Switching table for 2-level CHB Inverter

Switches Turn ON	Voltage Level
S1,S2	Vdc
S3,S4	-Vdc
S4,D2	0

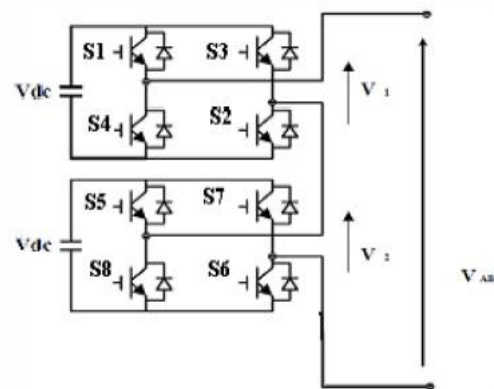

Fig2.5: Block diagram of 5-level CHB inverter model

The switching mechanism for 5-level CHB inverter is shown

Table2.2 Switching table for 5-level CHB Inverter

Switches Turn On	Voltage Level
S1, S2	Vdc
S1,S2,S5,S6	2Vdc
S4,D2,S8,D6	0
S3,S4	-Vdc
S3,S4,S7,S8	-2Vdc

3. FUZZY CONTROLLERS

Fuzzy control system gives the switching angles and frequency value. By using this value the harmonic contents present in the system are eliminated. The overall process takes place in proposed method is shown in Fig. 3.4. Feedback controller used here is to calculate voltage error values in the system. This voltage error values is given as the input to fuzzy control system. In the feedback controller, the voltage values are calculated from the voltage waveform for different time values. From the reference waveform voltage values at different time values are taken as reference

voltage value. Then for different time values, the voltage values are taken from the harmonics waveform and compared with the reference waveform. The voltage error values are calculated using the equation given below.

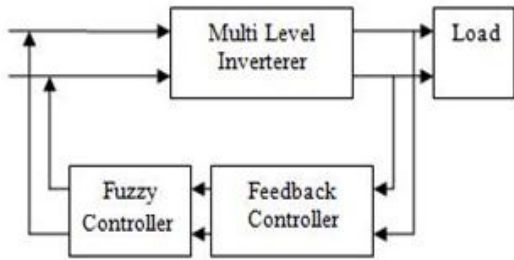

Fig3.1: Fuzzy Controller

After calculating the voltage error values, next step is to generate training dataset for training fuzzy system. Generating training dataset is one of the most important Processes because based on the training dataset only the Fuzzy control system will be trained

$$V_{error} = V_{ref} - V_h$$

Where V_{ref} is the voltage value of the system without Harmonics. The training dataset generated for training fuzzy System consists of n input variables and $s+1$ output Variables. Here, stands for number of voltage values taken For generating dataset, is the total number of dataset Generated, is the switching angle and stands for number of Switching angles.

The dataset generated for our proposed Method is shown below.

$$D = \begin{bmatrix} V_{t11} & V_{t12} & \dots & V_{t1n} \\ \vdots & \dots & \dots & \vdots \\ V_{tr1} & V_{tr2} & \dots & V_{trn} \end{bmatrix} \begin{bmatrix} \theta_{11} & \theta_{12} & \dots & \theta_{1n} \\ \vdots & \ddots & \ddots & \vdots \\ \theta_{r1} & \theta_{r2} & \dots & \theta_{rn} \end{bmatrix}$$

By using the above dataset, fuzzy system is trained. The fuzzy operation is explained briefly in the below Sections. After completion of training, fuzzy is used for Practical application. After completion of training fuzzy System the next step is to eliminate the harmonic contents in the system. First voltage error values are calculated using the equation 3. By giving voltage error values as input to the Fuzzy system, it gives corresponding frequency and switching angles as output. By applying this frequency and Switching angle values to the system the harmonic contents present in the system are eliminated. The frequency and switching angle are substituted in the equation given below

$$V(t) = V_h \sin(h \cdot 2\pi f_f t)$$

Where, f_f is the frequency obtained from fuzzy system.

$$V_h = \frac{4V_{dc}}{h\pi} \sum_{j=1}^s \cos(h\theta_j)$$

Where, θ_j is the switching angles obtained from fuzzy system and h is the harmonic order.

By substituting Equation in Equation we get the output dc voltage. The harmonics content eliminated or not is calculated using the below condition.

$$H_{eli} = \begin{cases} V_{ref}(t) = V(t); \text{harmonics eliminated} \\ V_{ref}(t) \neq V(t); \text{harmonics present} \end{cases}$$

A.CONSTRUCTION OF FUZZY CONTROLLER

The internal structure of the control circuit. The control scheme consists of Fuzzy controller, limiter, and three phase sine wave generator for reference current generation and generation of switching signals. The peak value of reference currents is estimated by regulating the DC link voltage. The actual capacitor voltage is compared with a set reference value. The error signal is then processed through a Fuzzy controller, which contributes to zero steady error in tracking the reference current signal.

A fuzzy controller converts a linguistic control strategy into an automatic control strategy, and fuzzy rules are constructed either by expert experience or with a knowledge database. Firstly, the input Error ‘E’ and the change in Error ‘ΔE’ have been placed with the angular velocity to be used as the input variables of the fuzzy logic controller. Then the output variable of the fuzzy logic controller is presented by the control Current Imax

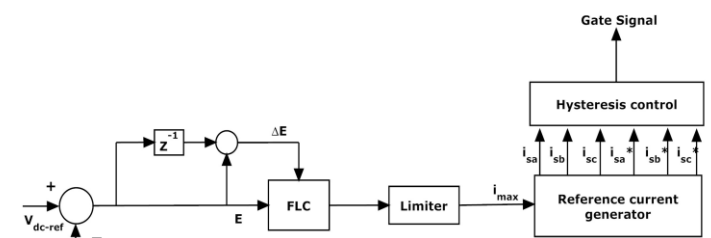

Fig3.2: Conventional fuzzy controller

To convert these numerical variables into linguistic variables, the following seven fuzzy levels or sets are chosen: NB (negative big), NM (negative medium), NS (negative small), ZE (zero), PS (positive small), PM (positive medium), and PB (positive big), as can be seen in Fig.3.14.

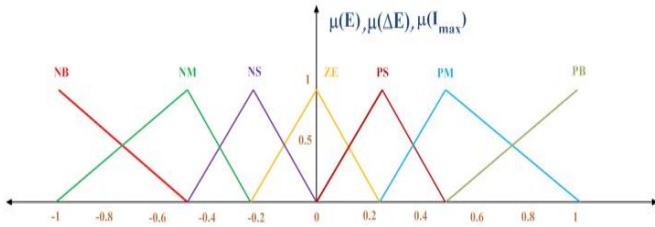

Fig 3.3:Membership functions for Input, Change in input, Output.

4. MATLAB/SIMULINK POWER CIRCUIT MODEL OF D-STATCOM

The power circuit model shows as 3-phase ac source, transmission line system, non linear load, DSTATCOM, control circuit, V-I measurements.

The DSTATCOM is connected across the non linear load, from that we obtained compensating currents, that are used to mitigate the harmonics, and compensation of reactive power.

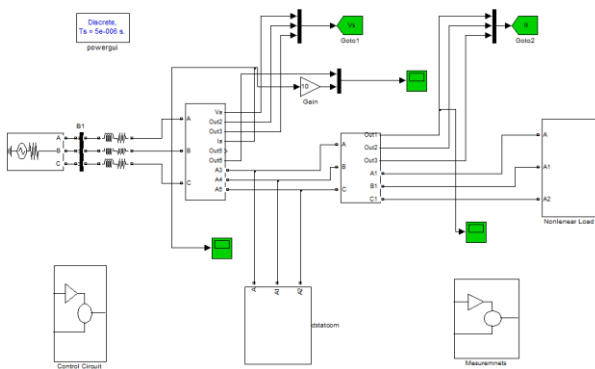

Fig4.1: Matlab/Simulink power circuit model for D-STATCOM

A.Source voltage, current and load current without D-STATCOM

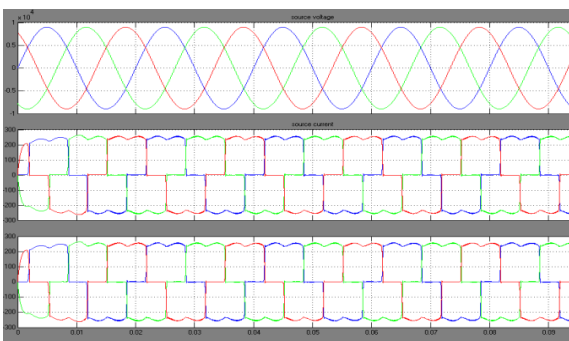

Fig4.2:Source voltage, current and load current without D-STATCOM

The general three phase ac voltage wave form obtained through three phase source. Fig shows the three phase source voltages, three phase source currents and load currents respectively without D-STATCOM. It is clear that without D-STATCOM load current and source currents are same.

B.Source voltage, current and load current with D-STATCOM

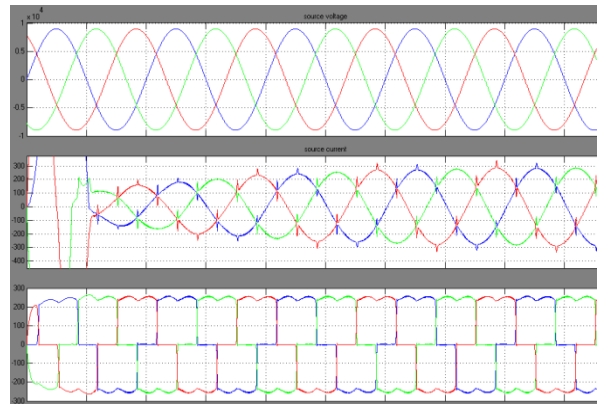

Fig4.3:Source voltage, current and load current with D-STATCOM

The three phase source voltages, three phase source currents and load currents respectively with DSTATCOM. It is clear that with DSTATCOM even though load current is non sinusoidal source currents are sinusoidal

Three phase source current that is given to by the supply, it consists harmonic content in its wave form as shown in

C.Output voltage of Five-level H-bridge inverter

The five levels are 1V, 0.5V, 0V, -0.5V, -1V. These 5 levels are obtained through cascaded H-Bridge 5-level inverter. It gives a single phase voltage, by providing transport delay for each phase in order to get 3-phase ac voltage from 5-Level Cascaded H-Bridge Inverter.

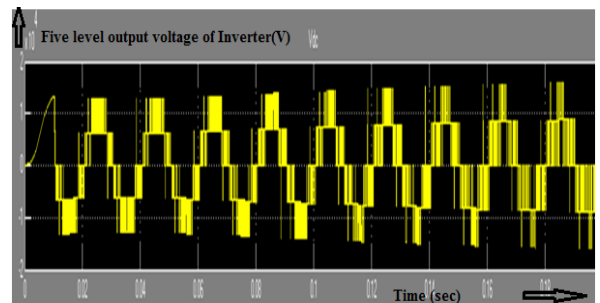

Fig4.4: Output voltage wave form of 5-level H-Bridge Inverter

D.Active power transferred to load with D-statcom

The active power can be improved with compensation of reactive power using DSTATCOM. Numerically average Real Power 4.5×10^6 Watts

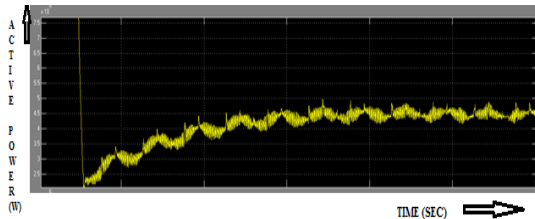

Fig4.5: Active power transferred to load with DSTATCOM

E.Reactive power transferred to load with D-statcom

The average reactive power almost near to 0 VAR, hence the reactive power compensation takes place with DSTATCOM.

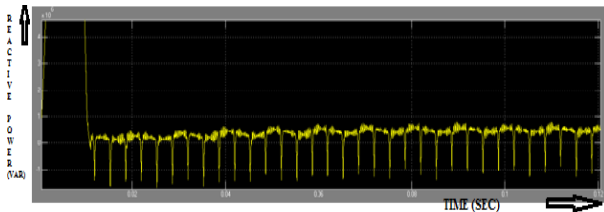

Fig4.6:Reactive power transferred to load with D-STATCOM

F.Harmonic spectrum of phase-a source current with and without D-statcom

Hence the Total Harmonic Distortion (THD) of source current without Dstatcom is 29.93% reduced to 6.19% with DSTATCOM.

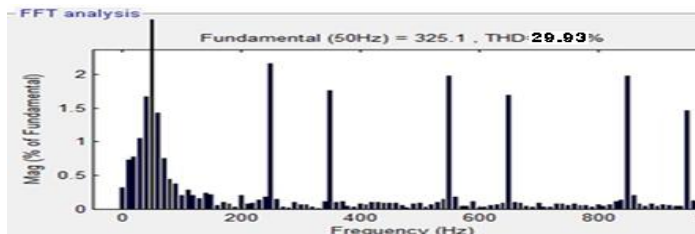

Fig4.7:Harmonic spectrum of phase-a source current with out DSTATCOM

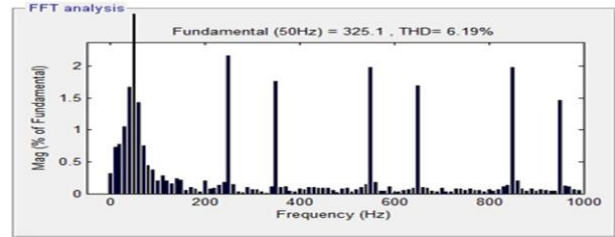

Fig4.8: Harmonic spectrum of phase-a source current with DSTATCOM

G.DSTATCOM WITH FUZZY LOOP CONTROLLER

The Source Voltage, Source Current, and Load Current, of Proposed Cascaded Multilevel Inverter Based DSTATCOM under Inductive load condition with Fuzzy Logic Controller.

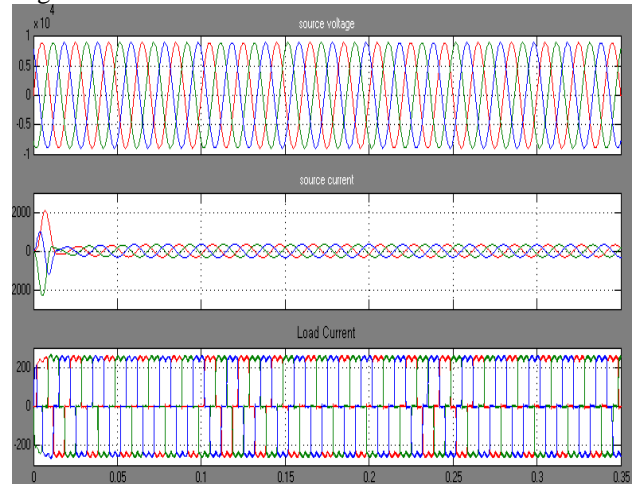
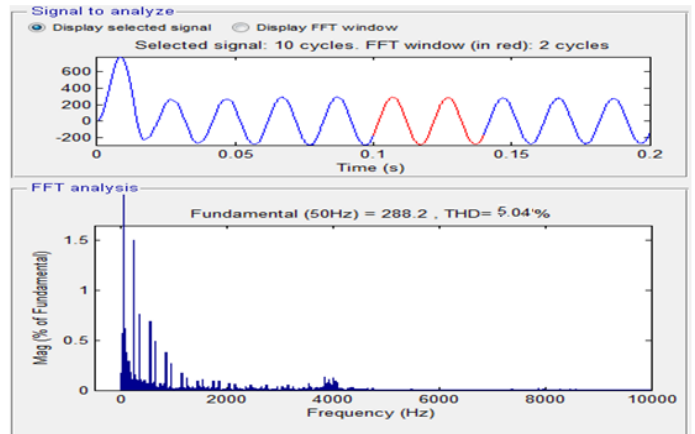

Fig4.9:Source Voltage, Source Current, Load Current with FLC

H.Harmonic spectrum of phase-a source current with FLC



4.10: Harmonic spectrum of phase-a source current with FLC

FFT Analysis of Source Current of Proposed CMLI Based DSTATCOM with Inductive Distorted Load Condition with fuzzy logic controller, here we get the Total harmonic distortion valve is 5.04%

1. PWM for Multilevel Inverter

There are 2 types of PWM techniques for Multilevel Inverter.

1. Phase shifted Carrier PWM
2. Level Shifted Carrier PWM

1. Phase Shifted PWM

The Phase shifted carrier pulse width modulation. Each cell is modulated independently using sinusoidal unipolar pulse width modulation and bipolar pulse width modulation respectively, providing an even power distribution among the cells. A carrier phase shift of $360^\circ / m_C$ (No.of levels) for cascaded inverter is introduced across the cells to Generate the stepped multi level output waveform with lower distortion.

If the Number of voltages $m=5$, the number of carriers required are $m_C-1=4$ and the Phase shift= $360^\circ / m_C =90$

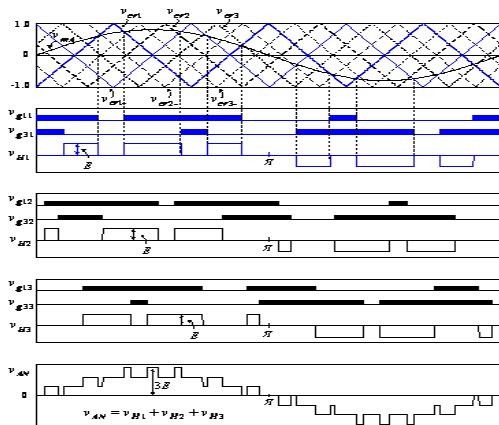

Fig. 4.11 Wave form of Phase Shifted PWM

2. Level shifted PWM

The Level shifted carrier pulse width modulation. Each cell is modulated independently using sinusoidal unipolar pulse width modulation and bipolar pulse width modulation respectively, providing an even power distribution among the cells. A carrier Level shift by $1/m$ (No.of levels) for cascaded inverter is introduced across the cells to generate the stepped multilevel output waveform with lower distortion.

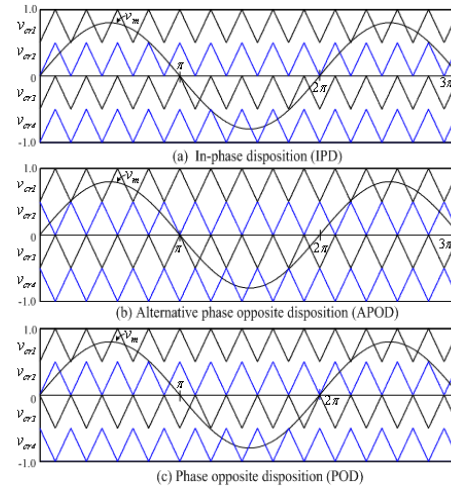

Fig. 4.12 Wave form of Level Shifted PWM

Comparison between the level shifted PWM scheme without, with D-statcom & with Fuzzy Controller

compariso ns	Without D-statcom	D-statcom (pi controller)	D-statcom (fuzzy controller)
THD of Source Current	29.93%	6.19%	5.04%

5.CONCLUSION:

A D-STATCOM with five levels CHB inverter is investigated. Mathematical model for single H-Bridge inverter is developed which can be extended to multi level H-Bridge. The source voltage, load voltage, source current, load current, power factor simulation results under non-linear loads are investigated for LSCPWM and are tabulated. Finally with the help of Matlab/Simulink based model simulation we conclude that Dstatcom fuzzy controller is better than the pi controller techniques and the results are presented.

Fuzzy loop controller based D-STATCOM in over distribution system

5.2 FUTURE SCOPE

The Reactive Power Compensation and Harmonics mitigation with fuzzy loop controller based D-STATCOM is the latest technology and is more effective use in future for distribution power systems. It can be further extend Neuro-fuzzy loop controller based D-STATCOM in power distribution system.

BIBLIOGRAPHY

- [1] K.A Corzine, and Y.L Familiant, "A New Cascaded Multi-level H-Bridge Drive," IEEE Trans. Power.Electron., vol.17, no.1, pp.125-131. Jan 2002.
- [2] J.S.Lai. and F.Z.Peng "Multilevel converters - A new breed of converters," IEEE Trans. Ind.Appl. .• vol.32. no.3. pp.S09-S17. May/ Jun. 1996.
- [3] T.A.Maynard. M.Fadel and N.Aouda. "Modelling of multilevel converter:" IEEE Trans. Ind.Electron .• vol.44. pp.356-364. Jun. 1997.
- [4] P.Bhagwat. and V.R.Stefanovic. "Generalized structure of a multilevel PWM Inverter:" IEEE Trans. Ind. Appln, Vol.IA-19. no.6, pp. 1057-1069, Nov./Dec .. 1983.
- [5] J.Rodriguez. Jih-sheng Lai, and F Zheng peng, "Multilevel Inverters; A Survey of Topologies, Controls, and Applications," IEEE Trans. Ind. Electron., vol.49, no.4., pp.724-738. Aug.2002.
- [6] Roozbeh Naderi, and Abdolreza rahmati, "Phase-shifted carrier PWM technique for General cascaded inverters," IEEE Trans. Power.Electron., vol.23, no.3, pp. 257-269. May.2008.
- [7] Bhim Singh, Kamal AlHaddad & Amrish Chandra, 1999, A Review of Active Filter For Power Quality Improvements, IEEE Trans on Industri Electronics, 46(S), pp.960970
- [8] Mauricio Angulo, Pablo Lezana, Samir Kouro, Jos'e Rodriguez and Bin Wu, "Level- Shifted PWM for Cascaded Multilevel Inverters with Even Power Distribution" IEEE Power Electronics specialist conference, 17-21 june 2007, pp.2373-2378.
- [9] B. P. McGrath and D. G. Holmes, "Multicarrier PWM strategies for multilevel inverters," IEEE Trans. Ind. Electron., vol. 49, no. 4, pp. 858- 867, August 2002..
- [10] K.A Corzine, and Y.L Familiant, "A New Cascaded Multi-level H-Bridge Drive," IEEE Trans. Power.Electron., vol.17, no.1, pp.125-131. Jan 2002.
- [11] J.S.Lai, and F.Z.Peng "Multilevel converters – A new breed of converters", IEEE Trans. Ind.Appl., vol.32, no.3, pp.509-517. May/ Jun. 1996. pp.960970